



**National Institute of Electronics and Information  
Technology,  
Electronics Niketan Building, 6, CGO Complex,  
Lodhi Road, New Delhi - 110 003, India**

**Request for Proposal (RFP)  
for  
Monitoring the presence of Employees  
through  
“Biometric Attendance Systems  
connected through  
web based infrastructure”**

[Reference No. 60(4)2013.NIELIT-HQ Dated 21-Jun-2013]

Place for opening of the bid	National Institute of Electronics and Information Technology (NIELIT), Electronics Niketan, 6, CGO Complex, Lodhi Road, New Delhi - 110 003, India
Last Date & Time of Submission of Bid	<b>30-07-2013 at 11.00AM</b>
Date & Time of Opening of Technical Bid	<b>30-07-2013 at 03.00PM</b>

Cost of Tender Document (Non-refundable): Rs. 1000/- Only (Rupees One Thousand Only)

## **NOTICE INVITING TENDER**

NIELIT invites competitive bids from the eligible bidders for supply and installation of Biometric Attendance devices as well as development and implementation of Web Based Application Software for “**Biometric Attendance System (BAS)**” along with the requisite support viz Testing, Training, Post-Implementation Support and Maintenance. The mandate is to monitor the presence of the employees using Biometric Attendance System through web based application. Schedule of dates is as under:

<b>Sr. No.</b>	<b>Activity/Milestone</b>	<b>Date/Place</b>
1.	<b>Release of RFP</b>	<b>21-06-2013</b>
2.	<b>Cost of Tender Document (non Refundable)</b>	<b>Rs.1000/-</b>
3.	<b>Earnest Money Deposit (EMD)</b>	<b>Rs. 10,000/-</b>
4.	<b>Estimated Cost</b>	<b>Rs. 20,00,000/-</b>
5.	<b>Document download Start Date</b>	<b>21-06-2013</b>
6.	<b>Document download End Date</b>	<b>29-07-2013</b>
7.	<b>Date and Time of Pre-Bid Meeting</b>	<b>02-07-2013 at 03:00 PM</b>
8.	<b>Bid Submission Start Date</b>	<b>08-07-2013</b>
9.	<b>Bid Submission End Date &amp; Time</b>	<b>30-07-2013 at 11.00AM</b>
10.	<b>Technical Bid Opening Date &amp; Time</b>	<b>30-07-2013 at 03.00PM</b>
11.	<b>Financial Bid Opening Date &amp; Time</b>	Will be intimated later to the Technically qualified bidders
12.	<b>Website for downloading Tender Document, Corrigendum's, Addendums etc.</b>	<a href="http://www.nielit.in">http://www.nielit.in</a> , <a href="http://eprocurement.gov.in">http://eprocurement.gov.in</a> , <a href="http://www.deity.gov.in">http://www.deity.gov.in</a>
13.	<b>Validity of RFP</b>	180 Days from the date of bid submission

Queries related to bid may be sent to **tender@nielit.in** latest by 01/07/2013 at 5.00 PM.

Managing Director NIELIT (HQ.) New Delhi
---

## INFORMATION TO BIDDERS

1. Application shall be considered in the prescribed Application Form only that is downloadable from the URL <http://www.nielit.in/tenders.aspx>. No physical sale of Application form will be done.
2. Interested applicants are advised to study the document carefully. Submission of Application shall be deemed to have been done after careful study and examination of the document with full understanding of its implications.
3. The Bidder shall bear all costs associated with the preparation and submission of its bid and NIELIT will, in no case, be responsible or liable for those costs, regardless of the conduct or outcome of the bid process
4. Bidders are advised to attach a letter from an authorized signatory of the company owning the patent of the technology being offered clearly detailing the deliverables / ownerships & rights for implementation, service, warranty and post sales support.
5. Each offer shall specify only a single solution which is cost effective and meeting the tender specifications and it is the responsibility of the Bidder to decide the best of breed solution.
6. **Excuse from Claim:** The Bidder at no point of time can excuse themselves from any claims by NIELIT whatsoever for their deviations in conforming to the terms and conditions, payment schedules, timeframe for implementation etc. as mentioned in RFP document.
7. **Adherence to Schedule:** The Bidder has to adhere to the time schedule of activities mentioned in the RFP and no request to change the last date or extend period / time for submission shall be entertained by NIELIT. However, NIELIT reserves the right to extend the date/time for submission of the responses without assigning any reason by notifying in its Website.
8. NIELIT reserves the right to separate the scope of hardware supply and any other licenses from the total contract and procure the same itself.
9. The Bidders would/may be asked to make presentation on technical and operational aspect including the demonstration of the technology submitted in form of the Bid.
10. **Submission of Bid:** The technical and financial bids should be submitted as mentioned in the Section-4. Submission of bids in any other format may result in invalidation of such bids. Any technical or financial bid submitted cannot be modified after the closing date and time for submission of the bids offers unless specifically permitted by NIELIT.
11. **Confidentiality of Process:** Information relating to the examination, clarification, evaluation and comparison of bids, and recommendations for the award of the Project shall not be disclosed to Bidders or any other persons not officially concerned with such process until the award to the successful Bidder has been announced.
12. **Right to Termination/Cancellation:** Notwithstanding anything contained in this document, NIELIT, reserves the right to cancel/terminate the bid/proposal process without assigning any reason whatsoever, at any time prior to signing the contract and NIELIT shall have no liability for above-mentioned actions.

### 13. AUTHENTICATION OF BID

The original and all copies of the Bid Document shall be signed by a person or persons duly authorized to bind the organization to the Contract. A duly stamped Power-of-Authority accompanying the Bid Document shall support the letter of authorization. The person or persons signing the Bid Document shall sign all pages of the Bid Document and each page of the bid document should be properly numbered. Corrections/findings in the bid shall be authenticated by signature of the authorized signatory. **All the Bidders have to abide by all the terms and conditions mentioned in this RFP.**

### 14. ENCLOSING OF BID

The bids shall be enclosed as mentioned in **Section 4** of this RFP.

### 15. ADDRESS FOR SUBMISSION OF BID

**Last date of submission of bid is 30-07-2013 at 11.00 AM**

Bid complete in all respect shall be delivered to:

**The Managing Director,  
National Institute of Electronics and Information Technology (NIELIT),  
Electronics Niketan Building,  
6, CGO Complex,  
Lodhi Road, New Delhi - 110 003, India**

In addition to the above, all envelopes including the inner envelopes shall indicate the name and address of the Bidder.

***If the outer envelope is not sealed and marked as required, NIELIT will assume no responsibility for the Bid's misplacement or premature opening.***

### 16. LATE BIDS

Any Bid received by NIELIT after the deadline for submission of Bids prescribed in this document, will be summarily rejected and returned unopened to the Bidder. NIELIT shall not be responsible for any postal delay or non-receipt / non-delivery of the documents. No further correspondence on this subject will be entertained.

### 17. OPENING OF TECHNICAL BIDS:

NIELIT will open technical bid as per schedule. The bidder may depute their representative (maximum 2 nos.) for the event. The Bidder's representatives who are present shall sign the attendance roll evidencing their attendance. Even if no representative of the bidder is available, the Bids would be opened as per schedule. In the event of the specified date of Bid opening/presentation being declared a holiday for NIELIT, the Bids shall be opened at the appointed time and location on the next working day.

**18. ANNOUNCEMENT OF BIDS:**

The Bidder's names, modifications, if any in the Proforma and the presence or absence of requisite fees and such other details will be announced at the opening of technical Bids. No bid shall be rejected at bid opening except for late bids.

**19. BIDS NOT CONSIDERED FOR EVALUATION:**

Bids which are rejected during any stage of the Bid evaluation process shall not be considered for further evaluation, under any circumstances.

**20. CLARIFICATION OF BIDS:**

To assist in the examination, evaluations and comparison of bids, NIELIT may, at its sole discretion, ask the Bidder for clarification on the bid submitted. The request for clarification and the response shall be in writing by post or email or by facsimile. If the response to the clarification is not received before the expiry of deadline prescribed in the request, the bid shall be rejected. No representation in this regard would be entertained after rejection of the bid.

**21. OPENING OF FINANCIAL BIDS:**

Financial Bids will be opened and compared after the technical evaluation. The financial bids will be opened of only technically qualified bidders. The name of Bidder, bid prices, total amount of each Bid, etc. shall be announced by NIELIT during opening of financial Bid.

NIELIT will prepare minutes of the Financial Bid Opening. The date, time and venue of opening of financial bid will be intimated later through e-mail/phone to the technically qualified bidders.

**22. COMPLETENESS OF BIDS:**

NIELIT will examine the Bids to determine whether they are complete, whether they meet all the conditions of the Tender Document and Technical Specifications, whether any computational errors have been made, whether required sureties have been furnished, whether the documents have been properly signed and whether the Bid Documents are substantially responsive to the requirements of the Tender Document. Information must be furnished in comprehensive manner against each column of Bid Document.

**23. RECTIFICATION OF ERRORS:**

Bidders are advised to exercise greatest care in entering the pricing figures. No requests regarding correction of mistakes in the financial bids will be entertained after the bids are opened. Any interlineations, erasers, alterations, fluid-marking, additions or overwriting shall be valid only if the person or persons signing the bid have authenticated the same with his/her signature. Arithmetic errors in bids will be corrected as follows:

- Where there is a discrepancy between the amounts in figures and in words, the amount in words shall govern.
- Where there is a discrepancy between the unit rate and the line item total resulting from multiplying the unit rate by the quantity, the unit rate will govern unless, in the evaluation committee, there is obviously a gross error such as a misplacement of a decimal point, in which case the line item total will govern or whichever is logically correct.
- Notwithstanding the above the decision of the Evaluation Committee shall be final and binding.

**24. REJECTION OF BID:**

The Bid shall be submitted in the form of typed document in original. Bids submitted by Telex, fax or email would not be entertained.

Bid may be rejected at any stage of the evaluation if it is found that the company has provided misleading information or has been black-listed by a central or any state government or has indulged in any malpractice/ unethical practice and has not honored contractual obligation elsewhere.

A bid that does not meet all pre-qualification criteria or is not responsive shall be rejected by NIELIT and may not subsequently be made responsive by correction or withdrawal of the nonconforming deviation or Reservation by the Bidder.

The bidder may seek reason/clarification for rejection of its bid.

**25. VALIDITY OF BID:**

Bids shall be valid for acceptance for a period of at least 180 (One Hundred and Eighty) days from the last date for submission till signing of the agreement or furnishing the Performance Security, whichever is later. The Bid with any lesser validity period is liable to be rejected.

**26. UNDERTAKING FOR REASONABLENESS**

The bidder will give an undertaking with financial bid that to the best of their knowledge and belief:

- a. Tendered rates are at par with the prevailing market rates and not more than the price usually charged for secure code of same nature/class or description from any private purchaser either foreign or as well as Government purchaser.
- b. In respect of indigenous items for which there is a controlled price fixed by law, the price quoted are not higher than the controlled price.
- c. Services/Products/Goods supplied, will be of requisite specification and quality.

**27. PRE-BID CONFERENCE:**

NIELIT will host a Pre-Bid Conference of prospective bidders, as per the schedule provided. The representatives of the interested organizations may attend the pre-bid conference at their own cost. The purpose of the conference is to provide bidders with information regarding the RFP and the proposed requirements. It will also provide each bidder with an opportunity to seek clarifications regarding any aspect of the RFP. A maximum of two representatives of each Bidder shall be allowed to participate in the conference. The venue for the Pre bid conference is the address provided below:

**National Institute of Electronics and Information Technology  
Electronics Niketan Building,  
6, CGO Complex, Lodhi Road,  
New Delhi - 110 003**

**28. ENQUIRIES AND CLARIFICATIONS:**

- i. The prospective bidders are free to question the bidding conditions and bidding process. However, such questions/disagreements with the provision in RFP should reach NIELIT on or before the date for Pre-Bid Conference.

- ii. All clarifications that are received by email on or before the date mentioned in the schedule will be addressed by NIELIT in a Pre-bid Meeting. NIELIT shall aggregate and respond to all such clarifications as per the schedule of bidding. This response to clarifications will be issued as a Corrigendum to the original RFP, if need be
- iii. During the course of Pre-Bid conferences, the Bidders will be free to seek clarifications and make suggestions for consideration. NIELIT shall endeavor to provide clarifications and such further information as it may, in its sole discretion, consider appropriate for facilitating a fair, transparent and competitive Bidding Process.
- iv. In respect of clarifications sought, the following shall apply:
  - NIELIT reserves the right not to consider any condition that is found unacceptable.
  - If in NIELIT's opinion, certain conditions are acceptable, in whole or in part, the same shall be finalized by NIELIT and the accepted conditions will be incorporated in the RFP.
  - In respect of suggestions / alterations proposed, NIELIT may consider them and the result will be circulated to all bidders.
- v. If NIELIT deems it appropriate to revise any part of this RFP or to issue additional data to clarify an interpretation of the provisions of this RFP, it may issue supplements to this RFP. Such supplemental information, including but not limited to, any additional conditions, clarifications, minutes of meeting, official communication over email/ post, etc. will be communicated to all the bidders by e-mail. Any such supplement shall be deemed to be incorporated by this reference into this RFP.
- vi. In order to allow bidders a reasonable time to take the amendment(s) into account in preparing their bids, NIELIT, at its discretion, may extend the deadline for the submission of bids. Designated Contact person is:

Dr. Sanjeev Gupta, Joint Director (Technical)  
National Institute of Electronics and Information Technology,  
Electronics Niketan, 6, CGO Complex, New Delhi – 110 003, India  
Ph No: +91 11 24363733  
Email: tender@nielit.in

### ABBREVIATIONS & DEFINITIONS

Authorised Signatory	The bidder's representative/ officer vested (explicitly, implicitly, or through conduct) with the powers to commit the authorizing organization to a binding agreement. Also called signing officer/ authority having the Power of Attorney (PoA) from the competent authority of the respective Bidding firm.
Bidder	"Bidder" means any firm/ agency/ company/ contractor/ supplier/ vendor responding to Invitation for Bids and which is participating in the Bid. Also called "Offer-or" or "Quoter".
Contract	"The Contract" means a legally enforceable agreement entered into between NIELIT and the selected bidder(s) with mutual obligations.
CMC	Contract Monitoring Committee.
Day	"Day" means a working day as per Government Of India (GoI).
DeitY	Department of Electronics & Information Technology, Government of India (GoI).
EMD	Earnest Money Deposit.
GoI	Government of India.
Goods	"Goods" means a tangible physical product that can be contrasted with a service which is intangible i.e. all the products which the bidder is required to supply to Purchaser under the Contract.
LoI	Letter of Intent
NIT	Notice Inviting Tender.
PC	Procurement Committee
PSD	Performance Security Deposit (also called as SD/Bank Guarantee, for details see below)
Purchaser/ Authority	Tendering Person or entity that is a recipient of goods or services provided by a seller (bidder) under a purchase order or contract of sale;also called buyer. NIELIT in this RFP document.
RFP	Request for Proposal (Bid document), an early stage in procurement process, issuing an invitation for suppliers, through a bidding process, to submit a bid on a specific commodity or service.
NIELIT	National Institute of Electronics and Information Technology.
SLA	Service Level Agreement is a negotiated agreement between two parties wherein one is NIELIT and the other is the service provider. It is a service contract where the level of service is formally defined. In practice, the term SLA is sometimes used to refer to the contracted delivery time (of the service) or performance.
Security Deposit (SD)	Submission of the 10% Amount of the Order Value by the Bidder and is retained till the successful completion of the project (as long as the bidder fulfils the contractual agreement).
Services	"Services" means the services to be delivered by the successful bidder and as required to run the project successfully as per the Contract. A service is the intangible equivalent of an economic good.
SoW	Scope of Work
Project Site	"The Project Site", wherever applicable, means the designated place or places.
STQC	Standardization Testing and Quality Certification
GIGW	Guidelines to Indian Government Website
CMS	Content Management System
CMAF	Content Management and Approval Policy
Application Development / Project	Website Development of website / web portal / web enabled application / application website development
SSP	Software Service Provider
SDD	Software Design Development
SRS	Software Requirement Specification



**TABLE OF CONTENTS**

<b>Sr. No.</b>	<b>SUBJECT</b>	<b>Page No.</b>
1.	Introduction to NIELIT	10
2.	Scope of Web-based Biometric Attendance System (BAS)	12
3.	Eligibility Criteria	22
4.	Bid Response Format	24
5.	Bid Evaluation	25
6.	General Terms and Conditions	26
7.	Annexure I - Application Form	44
8.	Annexure II - Letter of undertaking	47
9.	Annexure III - Financial Bid	48
10.	Annexure IV - Format for providing CVs for Project Manager, Team Leader and Team Members	49
11.	Annexure V - Self-Declaration – No Blacklisting	51
12.	Annexure VI - Format Power of Attorney	52
13.	Annexure VII - Representative Authorization Letter	53
14.	Annexure VIII - Bank Guarantee	54
15.	Annexure IX - Pre-Bid Queries Format	56
16.	Annexure X – Format for Deployment Requirement	57
17.	Annexure XI– Minimum Technical Specification	58
18.	Annexure XII– Employee Details	59

## Section 1 - Introduction to NIELIT

NIELIT (erstwhile DOEACC Society) is an Autonomous Scientific Society under the administrative control of Department of Electronics and Information Technology (DeitY), Ministry of Communications and Information Technology, Govt. of India. It was set up to carry out Human Resource Development and related activities in the area of Information, Electronics & Communication Technologies (IECT).

The Society, has its presence at 26 locations i.e. at Agartala, Aizawl, Ajmer, Aurangabad, Calicut, Chandigarh with branch office at Shimla, Chennai, Delhi, Gangtok, Gorakhpur with branch office at Lucknow, Guwahati / Tezpur, Imphal, Itanagar, Kohima / Chuchuyimlang, Kolkata, Churachandpur (Manipur), Lunglei (Mizoram) /, Patna, Shillong and Srinagar/Jammu with its Head quarters at New Delhi.

The Society is engaged in carrying out Education & Training Programs - both in the Formal & Non- Formal sectors in the area of IECT. Its mandate includes development of Industry oriented quality education and training programs in the state-of-the-art areas, to establish standards and to be the country's premier institution for Examination and Certification in the field of IECT. It is also a National Examination Body, which accredits institutes/organizations for conducting courses in the non-formal sector Education in the field of IT and related areas.

NIELIT Centres are conducting long-term courses at Post-Graduate level (M.Tech) in Electronics Design & Technology, Embedded Systems etc. which are not normally offered by Universities/Institutions in the formal sector. Other long term courses conducted by the Centers are Diploma Level courses in Electronics Production & Maintenance, Electronic Engineering, Computer Science & Engineering, Masters in Computer Application, and Bachelor in Computer Applications etc., which are affiliated to respective State Universities/Technical Boards.

As for non-formal Sector, the NIELIT Centres are conducting various long term courses viz. NIELIT 'O', 'A', 'B' & 'C' level Courses, Computer Hardware & Maintenance O/A Level and O/A/B level courses in Bio-informatics, Entrepreneurship development, etc. depending upon the demand in respective region. NIELIT also offers Course on Computer Concepts (CCC), Basic Computer Course (BCC), Awareness Computer Course (ACC), which are basically IT Literacy Level Courses for anybody and everybody.

The NIELIT Centres are also imparting training in Short Term Courses in the areas of Information Technology, Electronics Design & Technology, Manufacturing Technology, Maintenance Engineering, ITES-BPO etc. Besides the training activities, NIELIT Centres are offering consultancy services and undertaking software development projects in addition to Govt. sponsored projects in the area of Education & Training, R& D, etc.

### **Vision**

To be the leader in development of industry oriented quality education and training in the state of the art areas, establish standards and be the country's premier institution for examination and certification in the field of Information, Electronics and Communications Technology (IECT)

## Objective

The main objectives of NIELIT are

- To generate quality manpower and develop skilled professionals in the area of Information, Electronics & Communications Technology (IECT) and allied fields, by providing world class education & training and accreditation services.
- To provide continuing support to learners and trainers through active design & development of innovative curricula and content aligned with the dynamically changing IECT scenario as and when required.
- To establish a globally recognized quality system of examination and certification and provide a fair assessment of the competency of students.
- To continue to implement various NIELIT Schemes in the Non- Formal Sector in the IECT area.
- To establish standards in the area of IECT and to develop market oriented courses in the emerging areas as per the need.
- To impart continuing education for up-gradation of knowledge and skills of Industry professionals & academicians considering high obsolescence in the area of IECT.
- To provide entrepreneurship development program in the area of IECT.
- To develop and promote the culture of market to encourage and nurture industry oriented design and development.
- To provide Consultancy and Services to Government and non-Government Organizations in IECT

## Activities of the NIELIT (HQ) and its Centres

Core activities of the Society - Education & Training in the area of Information, Electronics and Communication Technology (IECT) are different from other educational programs of similar nature, in scope and quality, in the following aspects:

- Flexible programs with consistent and timely updating of Course Curricula to conform to industry needs, so that the students graduating from the Society should not only find employment but also be sought after by the Industry,
- Industry participation in the formulation and running of programs, particularly for imparting hands-on-experience.
- Latest Technology is used in all operations of the Society.
- Regular feedback from customers i.e. students and Industry

The above IT Education & Training Programs are categorized as follows:

- IT Education & Training for fresh students;
- Continuing Education (Refresher training/up-gradation) for working professionals through Short-Term/Long-Term Courses;
- Training of Trainers at various levels; and
- New courses in emerging areas of IECT

The Society is also engaged in Data Processing, Software Development and Consultancy projects in addition to Education & Training Programs.

## SECTION 2 – SCOPE OF WEB BASED BIOMETRIC ATTENDANCE SYSTEM (BAS)

### 2.1 Introduction

NIELIT is looking for supply and installation of Biometric devices for marking Attendance as well as design and development of a web based attendance system for monitoring the presence of its employees at NIELIT HQ and its offices at the 25 locations across India. The objectives for implementation of such a system are:

- To facilitate the marking of attendance through biometric devices at all NIELIT offices including HQ.
- To monitor the presence of employees at the NIELIT HQ/Offices which will give an overview of the timing discipline of the entire organisation.
- To provide the facility for monitoring the attendance of all employees from a central location i.e. HQ to be able to generate various attendance reports on a click.
- To provide requisite information to the authenticated users of the system.
- Integration with Leave Management System to reduce the load of manual processing of attendance by Admin section.

NIELIT intends to award work to competent and professional firms involved in Web Based Application Software Development to develop and implement an “**Web-based Biometric Attendance System for NIELIT**” along with requisite support viz supply and installation of biometric devices at required NIELIT offices, design and development of web-based attendance system, testing, training, post-implementation support and maintenance. Application Software to be developed shall meet the requirements and hosted at NIELIT/NIC Data Centre.

### 2.2 Detailed Process

The Process for BAS will be as follows:

1. Biometric Device: Sufficient number of biometric devices for marking attendance will be installed at each NIELIT Office.
2. Biometric Attendance: The Application will be used by 26 NIELIT Centre/BO/Extension Centers including HQ with the help of Biometric Devices supplied by Bidder.
3. Registration: Every officer/ official will register his/ her thumb/finger print impression with system for the use of attendance marking through biometric machine. The registration will be done for minimum of 4 fingers/ thumb in the system.
4. Marking of Attendance: Registered officer/ official can mark his/ her attendance using biometric machine installed in offices on daily basis. In case of problem during marking of attendance, there should be facility of USER ID based attendance and supplier/bidder shall take necessary action to ensure that the system recognizes the biometric details of every employee.
5. Attendance Management: To control and monitor the daily attendance and updations of the system, NIELIT will nominate a Nodal Officer responsible for all the activities of attendance monitoring.

## 2.3 Scope of the Work

Bidder would be responsible for the following scope of services:

- i. System Study, Design and Development of web Based **Real Time** Biometric Attendance System (BAS).
- ii. Supply and installation of at least two Biometric devices per location within defined time period. One for Managing Director/Director and one each for a group of 25 employees, per location. The Centre wise count of staff is at annexure-XII.
- iii. Integration of devices with the developed BAS. All installation /transportation charges will be borne by bidder.
- iv. Building Master Data by registering all the employees biometrically in the system
- v. Post Implementation Support /Warranty of 1yr free of cost.
- vi. Annual Maintenance Contract for Application software and Biometric Devices
- vii. Help desk support during warranty and AMC period
- viii. Integration with Leave Management System
- ix. Covers all offices existing as well as extends to centres that may be setup subsequent to award of contract.

### Detailed Scope of the Work

#### 2.3.1 Installation of Biometric Device

Procurement, Supply and Installation of Biometric Attendance devices at Nielit HQ and all NIELIT offices (presently 25) across India confirming the minimum technical specifications mentioned in RFP having central server at NIELIT/NIC Data Centre. In future, if new NIELIT offices are established, the bidder should supply the comparable and compatible configuration devices and carry out all the installation and integration with the existing system on mutually agreeable terms and conditions. ***Biometric Machines already installed in NIELIT offices should also be utilized with BAS.*** The installed biometric device should have features as under:

- i. The biometric devices should be of good quality with proper display screen enclosed in a tamper proof box.
- ii. The device should be able to operate in temperatures of 0-50°C and humidity range of 20-95%.
- iii. The FAR/ FRR should be less than or equal to .0001%.
- iv. The devices should be covered under *warranty for at least 1 year and AMC thereon.*

#### 2.3.2 Design, Development and Implementation of a web based application

NIELIT has envisaged following activities pertaining to Application Software that are required to be taken up by the Bidder to achieve the objectives:

- i. To conduct the System Study and to finalize the requirements in consultation with NIELIT. The system should be highly secure and customizable with following features:
  - a) Import of Employee data through Excel file
  - b) Employee Self Service Login
  - c) Employee Search & Query module

- d) Organization calendar
  - e) Outside office/Late permission
  - f) Real Time Attendance management across multiple offices
  - g) Integrates in real time with other modules like Leave management
  - h) Flexible Timing Provisions
  - i) Scope for modifications on change of the rules.
- ii. Develop “Visual Prototype” and obtain approval from NIELIT, Preparation and submission of SRS, SDD, etc.
- iii. Development of Web-based Application Software after getting approval of prototype software having features as under:
- a) Storage of attendance information at the central server located at NIC/NIELIT Data Centre from all NIELIT locations on real-time basis.
  - b) MIS Reports (Details may be provided at the time of SRS)
  - c) User-based access to various attendance reports.
  - d) Generation of periodic attendance reports for HQ as well as for NIELIT offices
  - e) Tracking of late-coming, special duty, overtime etc of employees across the NIELIT Offices.
  - f) Monitoring of Check In and Check Out of the officials of the organization at all NIELIT Offices/HQ.
  - g) Provision of mass late attendance, Informed/On tour/Prior Intimation.
  - h) Search of employee in any NIELIT Office/HQ based on multiple parameters like employee name, department, section etc.
  - i) Provision of leave deduction by authorized user.
  - j) The software should be developed using the best industrial practices.
- iv. There should be an alternate method of marking attendance in case the device is not able to mark the attendance of employees through biometric.
- v. **Testing:** The bidder shall thoroughly test the software for load, quality and performance along with proper functioning at its site before deployment of the software on production environment.
- a) In addition to above, NIELIT may hire services of third party to certify the software for load, quality and performance at its own cost to ensure proper functioning of the software. The suggestions given by the third party, if any would be mandatory for the bidder to implement and to incorporate and to execute the same from time to time.
  - b) Final approval/User Acceptance of the software and system shall be given by NIELIT after the testing and successful implementation.
  - c) The web based BAS developed and tested shall be hosted at NIELIT/NIC Data Centre and maintained by the bidder. The bidder shall be required to provide performance tuning parameters/configuration of the Server/OS/Application Server software on which the application would be installed to the team of NIELIT/NIC Data centre for efficient working of the Application Software.

- vi. **Security Audit:** Get the application audited for “Safe to Host” certification from CERT-in empanelled vendors before deploying the software in production environment in NIELIT/NIC Data Centre. The cost of security audit will be borne by the bidder only.
- vii. **Deployment of System:** Deployment shall include implementation and maintenance of the developed software.
  - a) It is necessary that the bidder should submit ideal minimum deployment requirements for the proposed Application Software which will be sufficient for the smooth functioning of the system without compromising the performance.
  - b) These deployment requirements should consist of minimum required hardware, software, and networking items / components which NIELIT needs to arrange for the successful installation and implementation of BAS. The deployment requirements should be submitted along with Technical Bid in the format given in Annexure X.
  - c) The successful bidder would deploy the Online Application Software on the infrastructure provided by NIELIT consisting of but not limited to Hardware, System Software, Networking Equipments and Network Bandwidth in NIELIT/NIC Data Center
- viii. Submission of user manuals and technical manual of the developed application.
- ix. **Application Software with source code in two sets of DVD/ CD ROMs along with source code and/or license of third party API/any other software used** Warranty of one year and AMC thereon to NIELIT over the software after User Acceptance Testing (UAT).
- x. The bidder shall be responsible for creation of Master Data regarding NIELIT employee data, their leaves etc. required for implementation of BAS under the supervision of Admin Section at NIELIT HQ and all NIELIT offices.
- xi. Hands on Training over the Application Software:**
  - a) The bidder shall provide hands on user training to the NIELIT staff for proper functioning of BAS.
  - b) The training shall be conducted for two days at each NIELIT Offices.
  - c) The Training Plan shall be mutually decided between NIELIT and the Bidder.
  - d) Training shall be provided on the basis of Training to Tutor model.
  - e) During training, user manuals for the Application Software shall be provided by the successful bidder.
  - f) The bidder must include all travelling, boarding, lodging cost in financial cost.
- xii.** The system shall be deployed on centralized server at NIELIT/NIC Data Centre and database enabling generation of different consolidated attendance and MIS reports for decision making by concerned departments.
- xiii.** The system should support integrated powerful MIS with minimum following reports:
  - a. Daily Attendance Report
  - b. Attendance Register
  - c. Machine wise Attendance Report

- d. Time wise Attendance Report
- e. Leave status report of employee
- f. Daily Checkout report
- g. Employee Check-in and Check-out Log Report
- h. Summary of Late coming employees
- i. Summary report of punctual Employees for a specified period
- j. Attendance Summary Report etc.

**2.3.3 Post Implementation Support/Warranty** (Support after UAT): The Bidder shall be responsible for installation, administration and maintenance of the Application Software and Biometric Devices for a period of 1 year after successful implementation in all the offices.

- During the warranty term, the bidder shall perform all the upgrade/new version update free of cost.
- Any call shall have to be attended within 24 hours and any software issue shall be resolved within 3 days or as mutually decided upon. In case the solution requires more time, the bidder should report to the concerned nodal officer within given time frame in writing with the requisite details for approval.
- **One full time person competent to handle the complete software and hardware should be deployed for the following responsibilities:**
  - Manage the Project/Devices/integration/Installation etc.
  - Provide timely reports from the System to the concerned authority/representative of NIELIT.
  - He shall be single point of communication between NIELIT and Bidder for complete contract period.
  - Provide the necessary support for ensuring the Integrity of Data.
  - He would be responsible for coordination for Hardware support as well as application support.

a) Application Software

- ✓ Ensuring uptime of the Application.
- ✓ Troubleshooting/Bugs removal: The successful bidder is required to provide troubleshooting support if any bugs are encountered during implementation of the software.
- ✓ Up-gradation of Software: Any modifications and/or enhancements / up-gradation required by NIELIT HQ/NIELIT Offices in the software during support period shall have to be incorporated by the successful bidder free of cost.
- ✓ Selected bidder will be required to incorporate amendments and enhancements from time to time and also to attend to any problem in day to day functioning of the system during this period free of cost.
- ✓ The Bidder would be responsible for deputing experienced virtual/ remote System Administrator (offsite) for the period of warranty/AMC for smooth implementation of application software.
- ✓ The Bidder shall be responsible for providing monthly/ yearly backups for application software.



- ✓ The bidder shall maintain a Maintenance Register/call register for logging complaints during post implementation support period. The firm shall essentially provide complaint number for each complaint call made by the user.
- b) Biometric Devices
  - ✓ The successful bidder should ensure proper functioning of the device.
  - ✓ The successful bidder should give comprehensive warranty/guarantee that the goods/stores/articles supplied continue to conform to the description and quality as specified in the RFP for a period of **One year from the date of installation** of the said goods/ stores/ articles notwithstanding the fact that the purchaser may have inspected and/or approved the said goods/stores/article.
  - ✓ If during the aforesaid period of One year, the said goods/ stores/ articles are found to be not confirming to the description and quality, the decision of the Purchase Officer in that behalf will be final and conclusive, the purchaser will be entitled to reject the said goods/ stores/ articles or such portion thereof as may be discovered not conforming to the said description and quality. On such rejection the goods/articles/ stores will be at the seller's risk and all the provisions relating to rejection of goods etc., shall apply. The bidder shall, if so called upon to do, replace the goods etc., or such portion thereof as is rejected by Purchaser, otherwise the bidder shall pay such damages as may arise by the reason of the breach of the condition herein contained. Nothing contained herein shall prejudice any other right of the Purchaser in that behalf under this contract or otherwise.

2.3.4 **Annual Maintenance Contract:** On expiry of warranty period, the BAS and related hardware will be under AMC with the vendor on the charges quoted and accepted under this contract. The AMC will initially be valid for one year, which may be extended on mutually agreed terms. During the AMC period, the bidder shall be responsible for management and maintenance of application software and its integration with devices, etc. The bidder shall take up all the activities as mentioned above in Section 2.3.3 (Post Implementation Support).

2.3.5 **Requirements and Expected Features of Proposed Web Based BAS**

- a) **Browser Independent:** The Application Software should be web enabled so that the same can be accessed from anywhere, anytime. It is imperative that the user interface of the Application Software should be browser based so that the users can access the software using internet (HTTP protocol). The software should be compatible with all popularly used browsers.
- b) **Software Platform:** The centralized web based Application Software should be developed using proven technology. The software should be compatible for deployment in three tier architecture environment. Source code should be well documented. NIELIT shall have the right to approve the coding practices and may ask the firm, at any time, to change full or some part of the code according to the pattern suggested.

- c) The software should have user friendly Graphical User Interface (GUI) and should enable role based access rights to each stakeholder. The interfaces needs to be developed for the users who will fall in the below major categories:
- i. **NIELIT (HQ):** Managing Director and the dealing staff responsible for monitoring the presence of employees across all locations
    - Generation of report of late-coming, special duty, overtime, employee-wise/ centre-wise/ department-wise attendance reports
    - Provision for approval of permissions for late coming, leave, tour, early leaving etc. of concerned employees
  - ii. **NIELIT Office/centre:** Centre Director and dealing staff responsible for:
    - Monitoring the presence of employees across all departments.
    - Generation of reports of late-coming, special duty, overtime, employee-wise/ department-wise attendance etc.
    - Provision for approval for late coming, leave, tour, early leaving etc. of concerned employees
  - iii. **NIELIT (HQ) – Head of Wings**
    - Monitoring the presence of employees of the Department.
    - Generation of reports of late-coming, special duty, overtime, employee-wise attendance etc.
    - Provision for approval for late coming, leave, tour, early leaving etc. of employees working under respective Wings
  - iv. **NIELIT (HQ)- Admin**
    - Addition and managing of multiple locations and departments at a location.
    - Addition and management of rights.
    - Define and assign access using biometric to employees.
    - Defining of departments, roles and rights to various users of BAS.
    - Creation and management of attendance rules, leave rules etc. of employees at HQ.
    - Defining and managing Holidays, Shifts, Special duties etc for HQ etc.
  - v. **NIELIT Centre – Admin**
    - Used-ID based authenticated access to the system.
    - Addition and managing of multiple departments at the Centre.
    - Addition and management of users and their roles and privileges at the Centre.
    - Defining and managing Holidays, Shifts, Special duties etc for the Centre etc.
  - vi. **NIELIT Users:**
    - System shall provide a singular access to each employee of NIELIT to mark his/ her attendance using the biometric device.

- Provision for application of leave, late coming, early leaving, permission for tour etc by the employee.
- Integration of application for leave, late coming, tour etc from registered mobile no. of employee.
- User-ID based access to attendance reports concerning the individual user etc.

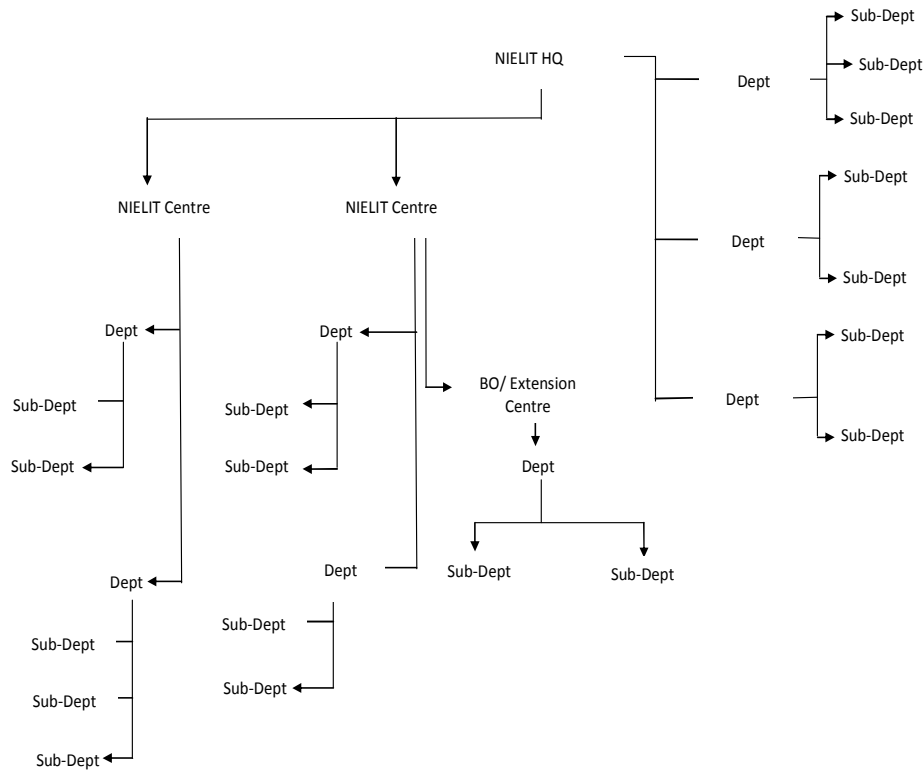

- d) **Performance Requirement:** System shall be able to support at least 1000 Concurrent Users within a response time of fraction of seconds.
- e) **Safety Requirement:** All critical transactions / operation which are being used to delete some records should be explicitly confirmed by the user with a prompted dialog box.
- f) **Security Requirement:** The application should be designed and developed by incorporating security features as per the best industrial practices. The specific elements of the application should be provided to authorize personnel only. Wherever required the data should be encrypted. The bidder shall, to the extent relevant and possible, be guided by the standard information systems security policies and guidelines or appropriate Industry standards while deploying application software. Appropriate access and authorization controls should be incorporated into the software. The bidder should also provide configurable User and Role-based security options for the application.

- g) **Administrator**: The Application Software shall have appropriate administrative features / options for Users with role-based access to various features especially user management, role management etc.
- h) **Audit Trail**: The Application Software should provide proper audit trail for any change made in the data. The software should be capable of storing the IP addresses, date and time stamp and other identities of the user modifying the information in the system. The system should maintain proper logs of any changes made in the data. System shall be implemented in such way that all critical transactions are stored with the logged-in user name that has performed that transaction.
- i) **Validation Checks**: The Application Software should have provisions for proper validation checks to minimize data entry mistakes so that garbage data is not stored in the database.
- j) **Transaction Accuracy & Consistency**: Application Software should ensure accuracy and consistency of data in database and reports. The transaction accuracy would be measured from the number of reported errors vis-à-vis number of transactions. The transaction data should meet (Atomicity, Consistency, Isolation, Durability) ACID property. The software should maintain 100% data accuracy and consistency.
- k) **Login & Authentication**: System shall provide a Unique User Id and shall provide necessary feature for user management including password management etc. All information concerning to NIELIT Office and NIELIT (HQ) shall be provided only after authentication.
- l) **Online Help**: The software should provide Online Help facility for the end-users to operate the software with ease and speed. The help may be in any of the forms viz. PDF file, PPT, Video etc.
- m) **Adherence to Guidelines** : The web based Application Software should comply with the guidelines for Indian Government Websites (GIGW) issued by Department of Electronics & Information Technology (DeitY), Government of India (GoI) and available at <http://web.guidelines.gov.in>.
- n) The bidder shall provide list of all the controls used in the software along with Developer's Information and Technical Documentation / Manual for usage of the controls.
- o) The bidder shall provide one copy each of User Manual, Design Manual and Technical Manual in both Hard and Soft copy.
- p) The Technical Manual should include Entity-Relationship (ER) diagram and descriptive schema of the database, Physical and Logical Data Flow Diagrams(DFDs), Use Case Diagrams and all other relevant technical documentation of entities such as tables, fields, queries, forms, reports, procedures etc.

## **2.5 DELIVERABLES**

### **Stage I**

- System Study Report
- System Requirement Specification Report (Soft copy as well as hardcopy)
- System Design Report (Soft copy as well as hardcopy)
- Prototype of Application Software
- Acceptance Testing Reports

- Web Based Application Software for BAS as approved by NIELIT (along with well documented source code), Technical Manual/SRS and User Manual, various reports as per SRS, etc. **The Application Software with source code** in two sets of CD ROMs along with source code and/or license of third party API/any other software used.
- Documents to be provided:
  - ✓ Soft Copy of User Manual of the Application Software
  - ✓ Soft Copy of Technical Manual of the Application Software.
- User Acceptance Certificate/GIGW status report

**Note: Soft copy should be in the form of doc/docx file and pdf both.**

### **Stage II**

- Security Audit Clearance certificate for hosting application.
- Training on the software developed
  - ✓ Class room training by trained instructor. Training manual to be provided to each participant during training.
  - ✓ Context-sensitive help/ online help/ visual tutorial should be available with the Application Software for online understanding of software.
- Software upgrades/enhancements
- Provide reports on implementation of software for various sections of the user department.

**Note: It is mandatory to provide all soft copies of the user manuals and reports.**

**2.6 Schedule for completion of tasks:** The entire scope of work has to be carried out by the developer firm on the “Prototype Based Approach”.

S.No.	Activity	Time Schedule
<b>Stage I: Supply of Biometric Devices and Development of web based BAS</b>		
1	Signing of Agreement/MOU	Within 7 Days from Date of Order
2	Supply & Installation of Biometric devices	2 Days before deployment of application software for testing at NIC/NIELIT Centre
3	System Study Report	Within 15 days from the date of signing of the agreement
4	Submission of SRS	Within 10 Days after System Study.
5	Approval of SRS from concerned departments.	10 days from date of submission of SRS
6	Development of Prototype along with submission of final SRS and SDD.	Within 15 Days of approval of SRS.
7	Acceptance of the prototype by NIELIT	Within 7 days from development of Prototype
8	Development and testing of Application Software	Within 30 days of approval of prototype
9	Delivery and deployment of final Application Software	Within 15 days after testing of beta version of Application Software
10	User Acceptance Testing (UAT)	Within 7 days from deployment of final version of software
<b>Stage II : Hosting of Biometric Attendance System (BAS)</b>		
1	Security Auditing by CERT-in empanelled vendors and security audit patching	Within 2 weeks of UAT.
2	Comprehensive Training and Support Services	As per mutually decided Training Plan. Logistic support for the training to be provided by NIELIT as per the requirement.
*Maximum Available Time For Stage I and Stage II – 120 days		

### SECTION 3 – ELIGIBILITY CRITERIA

#### Legal Requirements/ Compliance

- The bidder should be a Proprietorship Concern/Company registered under Indian Company Act, 1956/ Firm registered under The Partnership Act 1932/ Society registered under Societies Act, 1860/ Autonomous bodies or any other venture not covered above.
- The bidder should be in operations in the business of System Integration/ Software Development/ Software Customization & Implementation anywhere in India for at least Three Years as on last date for submission of Bid.
- The bidder must possess all valid certificates as mentioned below and should submit self attested copies:
  - ✓ VAT/Service Tax Registration Certificate
  - ✓ PAN Number
  - ✓ Income Tax Return for FY 2011-12
- The Bidder should have following certifications valid in force:
  - SEI-CMM Level-3 or higher and/or ISO: 9001:2008/ ISO 27001:2005 certificate for Software Development/technology center or IT enabled Service or/and Turnkey E governance projects.

#### Technical Requirements/ Compliance:

- The Bidder should have domain knowledge and experience of executing at least ONE assignment of providing similar services to any Government organization / Semi-Government organization/ PSU in India covering around 2000 employees where the value of the assignment should be at least Rs. 18 Lacs (A copy of Performance certificate/ completion certificates and the proof of payments and work done w.r.t. the relevant assignments shall be submitted).

OR

The Bidder should have successfully completed, during last 3 years, at least TWO assignments of providing similar services to any Government organization/ PSU's/Organization of repute in India where the value of each assignment should be at least Rs. 9 Lacs.

- The bidder should have a minimum strength of 15 software professionals on their rolls having minimum qualification of B.E. or B. Tech (CS/IT)/MCA/ DOEACC 'B' Level or equivalent with 5 years of relevant experience.

#### Financial Requirements/ Compliance:

- The Bidder should deposit Earnest money along with the Technical bid. The bid received without required Earnest money will be rejected.
- The Successful bidder should submit performance security @ 10% of the contract value in the form A/C payee demand draft/ pay orders/ Bank Guarantee/ FDR of any of the nationalized bank in favour of NIELIT, New Delhi within 15 days from the award of the contract, which remains valid up to 60 days beyond the date of completion of all contractual obligation of the firm/company.
- EMD shall be refunded to the successful bidder on receipt of performance security.

- The Bidder should have total annual Turnover of Rs. 2 crore per annum from IT/Software related services during the last three Financial years (Proof: Audited Balance Sheets for FY 09-10, FY 10-11 & FY 11-12 must be enclosed).
- The Bidder should have a positive net worth during each of the last three financial years (2009-10, 2010-11 and 2011-12). (Copies of Profit & Loss)

**Other Requirements/ Compliance**

- A bidder is not eligible to participate in this RFP while under sanction by NIELIT, whether such sanction was directly imposed by NIELIT, or imposed by NIELIT pursuant to the Agreement for Mutual Enforcement of Debarment Decisions. A bid from a sanctioned or cross-debarred firm will be rejected. Similarly, at the time of bidding, the firms having black-listed/ debarred in participating in any procurement activities by any State or Central Government in India are not allowed to bid. Undertaking to this effect shall be submitted by the bidder on his letter head.

## SECTION 4 – BID RESPONSE FORMAT

The bidder shall effectively communicate the solution and shall cover all the requirements as given in the RFP. The bidder shall use the following format to submit the response:

- ✓ The documents of the Technical Bid shall be placed in lacquer sealed envelope clearly marking "**Technical Bid**."
- ✓ The financial Bid shall be placed in separate sealed envelope clearly marking it as "**Financial Bid does not open with Technical Bid**".
- ✓ The above two envelopes shall then be placed in third envelope, which shall also be appropriately lacquer sealed and marked as '**Bid for Web-based Biometric Attendance System**'"

### CONTENTS OF ENVELOPE-1 (TECHNICAL BID)

- Covering letter and Application Form, Checklist of Submissions as per Annexure-I
- Letter of Undertaking regarding acceptance of terms and conditions as per Annexure-II.
- Documents Supporting eligibility Criteria
  1. Copy of the Certificate of Incorporation of the Company/ Firm's Registration Certificate.
  2. Copy of valid PAN, Service tax Registration number and Income Tax Return
  3. Copy of SEI-CMM Level-3 or higher and/or ISO: 9001:2008/ ISO 27001:2005 certificate
  4. Copy of experience statement supported by documents of work order/LOI/Contract/Certification on client letterhead/ Performance certificate/ completion certificates and the proof of payments and work done w.r.t. the relevant assignments.
  5. Audited Balance Sheets / CA Certificate in support of turnover criteria for last three financial years (2009-10, 2010-11 and 2011-12).
  6. DD of EMD and Tender fee of Rs. 11,000/- drawn in favour of NIELIT, payable at Delhi for (EMD Rs. 10,000/-+Tender fee Rs. 1000/-)
  7. Self Declaration Form as per Annexure-V.
- Self Certified CVs of 15 software professionals with qualification of B.E. or B. Tech. (CS/IT)/MCA/ DOEACC 'B' Level or equivalent with 5years of relevant experience as per Annexure-IV.
- Executive summary: The Executive Summary shall provide an overview of the Bidder's organization, Bidder's products and services provided as part of the procurement. A brief description of the unique qualifications of the Bidder shall then be provided followed by a summary on capabilities and past experience in implementing such projects.
- Requirement of H/W for deployment of BAS as per Annexure-X.
- Hardware Technical Specifications as per AnnexureX1.

### CONTENTS OF THE ENVELOPE-2 (FINANCIAL BID)

1. The Financial bid as per format in Annexure III.
2. One Soft copy of the Financial bid



## SECTION 5: BID EVALUATION

The Evaluation Committee (s) constituted by NIELIT shall evaluate the technical and financial bids. The Committee(s) may choose to conduct negotiation or discussion with Bidders as per the procedures of NIELIT. The decisions of the Evaluation Committee(s) in the evaluation of Technical and Financial bids shall be final and binding. No correspondence will be entertained outside the process of negotiation / discussion with the Committee(s). Bid Opening and Evaluation methodology described below facilitates the objective evaluation of technical and financial bid submitted by the bidders.

The participating bidders need to comply with the eligibility criteria as mentioned in “Section 3: Eligibility Criteria” for this project in terms of organizational, financial and technical experience, etc. Supporting documents need to be provided for each criterion. The bid will be rejected, in case it does not meet the eligibility criteria.

The evaluation of the bids will be carried out in following stages:

### **1) Technical evaluation:**

- The initial technical evaluation shall be completed by the designated Evaluation Committee(s) as early as possible after opening of technical bids.
- After the technical evaluation is completed, NIELIT shall inform the Bidders who have submitted bids, the detailed compliance of their Technical bids and shall notify those Bidders whose Bids did not meet the minimum technical criterion or were considered non- responsive to the RFP and Scope of Work.
- NIELIT shall notify the date, time and location for opening the Financial Bids to the technically qualified Bidders.
- In case the no. of bids qualifying the technical evaluation is less than three, the same will be processed only if the competent authority in NIELIT decides to do so for the reasons to be recorded in writing; otherwise fresh bids will be invited.

### **2) Financial evaluation:**

Based on the results of the technical evaluation, duly constituted financial evaluation committee will then proceed to open and evaluate the financial bids of the technically acceptable Bidders. The financial evaluation will take into account the information supplied by the Bidders in their financial bid. The Bidder shall furnish detailed break up of costs.

Financial bids shall be evaluated for only those Bidders who meet the terms and conditions of NIELIT and have technically qualified for this bid.

- The bidder will be evaluated based on the Total Cost for the proposed solution on turnkey basis.
- The prices, once offered, must remain firm and must not be subject to escalation for any reason whatsoever within the period of validity of the bid and subsequent contract, if any subject to change in the laws by the Govt. Authorities.

***Based on the price quoted by a bidder, the work will be allocated. All bids shall be ranked as L1, L2, L3 ... and work will be awarded to L1 (the lowest quote).***

## SECTION 6: GENERAL TERMS AND CONDITIONS

### 1) **Income Tax, VAT/ Service Tax Registration and Clearance Certificate**

No Dealer who does not hold a valid PAN from Income Tax department and who is not registered under the VAT/ Sales Tax and Service Tax Act prevalent in the State where his business is located shall submit the bid. The VAT/ Sales Tax and Service Tax Registration Numbers should be indicated.

### 2) **Contract Documents (Non – Disclosure Agreement)**

Subject to the order of precedence set forth in the Agreement, all documents forming the Contract (and all parts thereof) are intended to be correlative, complementary, and mutually explanatory.

### 3) **Interpretation**

- a) If the context so requires it, singular means plural and vice versa.
- b) **Commercial Terms:** The meaning of any trade term and the rights and obligations of parties there under shall be as prescribed by commercial terms. All the terms shall be governed by the rules prescribed in the current edition of commercial terms, published by the Indian Chamber of Commerce at the date of the Invitation for Bids or as specified in the bidding document.
- c) **Entire Agreement:** The Contract constitutes the entire agreement between the Purchaser and the Supplier and supersedes all communications, negotiations and agreements (whether written or oral) of parties with respect thereto made prior to the date of Contract.
- d) **Amendment:** No amendment or other variation of the Contract shall be valid unless it is in writing, is dated, expressly refers to the Contract, and is signed by duly authorized representatives of each party thereto.
- e) **No waiver:** Subject to the conditions (f) and (g) below, no relaxation, forbearance, delay, or indulgence by either party in enforcing any of the terms and conditions of the Contract or the granting of time by either party to the other shall prejudice, affect, or restrict the rights of that party under the Contract, neither shall any waiver by either party of any breach of Contract operate as waiver of any subsequent or continuing breach of Contract.
- f) Any waiver of a party's rights, powers, or remedies under the Contract must be in writing and signed by an authorized representative of the party granting such waiver, and must specify the right and the extent to which it is being waived.
- g) The contract shall be governed by the provisions of GFRs and instructions issued by various government organizations (e.g. but not limited to Ministry of Finance, CVC etc.) having jurisdiction to issue orders/instructions of procurement related matters. In case the provisions of Contract/Agreement/this Document are at variance with the Orders/Instructions issued by such government organizations; the Orders/Instructions will prevail.
- h) **Severability:** If any provision or condition of the Contract is prohibited or rendered invalid or unenforceable, such prohibition, invalidity or unenforceability shall not affect the validity or enforceability of any other provisions and conditions of the Contract.

- i) In case of any ambiguity in the interpretation of any of the clauses in the tender document, the interpretation of the clauses by Authorized Representative of NIELIT shall be final and binding on all parties.

#### **4) Language**

- a) The Contract as well as all correspondence and documents relating to the Contract exchanged by the Supplier/ Bidder and the Purchaser, shall be written in English and/or Hindi languages only or as specified in the special conditions of the contract.
- b) Supporting documents and printed literature that are part of the Contract may be in another language provided they are accompanied by an accurate and authenticated translation of the relevant passages in English language. Supporting material, which is not translated in English and/or Hindi, will not be considered for evaluation.
- c) For the purpose of evaluation and interpretation of the bid, English language translation shall prevail.
- d) The Supplier/ Bidder shall bear all costs of translation to the governing language and all risks of the accuracy of such translation.

#### **5) Notices**

- a) Any Notice given by one party to the other pursuant to the Contract shall be in writing to the address specified in the contract. The term “in writing” means communicated in written form with signatures. Faxes/emails shall be followed by written signed letter.
- b) A Notice shall be effective when delivered or on the Notice’s effective date, whichever is later.

#### **6) Governing Law**

The Contract shall be governed by and interpreted in accordance with the laws of the India.

#### **7) Time for Commencement and Completion**

- a) The Bidder shall commence work on the Facilities within the period specified and without prejudice, the Bidder shall thereafter proceed in accordance with the time schedule specified in the Implementation Schedule and any refinements made in the agreed and finalized Project Plan.
- b) The Bidder shall attain completion of the project or of a part where a separate time for completion of such part is specified in the Contract, within the time stated or within such extended time to which the Bidder shall be entitled.

#### **8) Delivery & Installation**

- a) Subject to the conditions of the contract, the delivery of the system and completion of the related services shall be in accordance with the delivery and completion schedule specified in the bidding document and/ or as per the award letter/contract. The details of supply/ shipping and other documents to be furnished by the Supplier are specified in the bidding document and/ or contract.
- b) The Contract for the supply can be repudiated at any time by designated Purchase Officer of NIELIT, if the deliveries are not made to his satisfaction after giving an opportunity to the bidder of being heard and recording the reasons for repudiation.

- c) The Supplier/ Bidder shall arrange to supply, install and commission the ordered materials/ system as per specifications within the specified delivery/ completion period at all NIELIT offices. NIELIT has its presence at 26 locations i.e. **Agartala, Aizawl, Ajmer, Aurangabad, Calicut, Chandigarh with branch office at Shimla, Chennai, Delhi, Gangtok, Gorakhpur with branch office at Lucknow, Guwahati / Tezpur, Imphal, Itanagar, Kohima / Chuchuyimlang, Kolkata, Churachandpur (Manipur), Lunglei(Mizoram), Patna, Shillong and Srinagar/Jammu with its Head quarters at New Delhi.**
- d) Shifting the place of Installation: The user will be free to shift the place of installation. The supplier shall provide all assistance, in shifting of the equipment. However, if the city/town is changed, additional charges of assistance in shifting would be decided mutually.
- e) Delivery Schedule will require the explicit written consent of the Client. The Bidder shall bear responsibility for deliveries and cost of transport to the Project Sites. Unless otherwise specified, the Bidder shall be free to use transportation through carriers registered in the Country.

#### 9) Supplier's/ Bidder's Responsibilities

The Supplier/ Bidder shall supply all the products and related services included in the scope of supply in accordance with the provisions of bidding document and/or award letter/contract.

#### 10) Purchaser's Responsibilities

- a) Whenever the supply of products and related services requires that the Supplier/ Bidder to obtain permits, approvals, and import and other licenses from various public authorities, the Purchaser shall, if so required by the Supplier/ Bidder, make its best effort to assist the Supplier/ Bidder in complying with such requirements in a timely and expeditious manner though the responsibility for obtaining such clearances and related expenditure would be of supplier/Bidder.
- b) The Purchaser shall pay all costs involved in the performance of its responsibilities, in accordance with the general conditions of the contract.

#### 11) Contract Price

- a) The Contract Price shall be paid as specified in the work/contract award letter subject to any additions and adjustments thereto, or deductions there from, as may be made pursuant to the Contract/prevaling law.
- b) Prices charged by the Supplier/ Bidder for the Products delivered and the Related Services performed under the Contract shall not vary from the prices quoted by the Supplier/ Bidder in its bid, with the exception of any price adjustments authorized in the special conditions of the contract.

#### 12) Terms of Payment

- a) The Supplier's/ Bidder's request for payment shall be made to the Purchaser in writing, accompanied by invoices describing, as appropriate, the related material supplied/services provided. The Service Provider will define the services performed and

substantiate with documents pursuant to general conditions of the contract and fulfillment of all the obligations stipulated in the awarded Contract documents.

- b) Payments shall be made promptly by the Purchaser as per the quoted rates and as per payment schedule after submission of an invoice (in duplicate) for payment by the Supplier/ Bidder accompanied by proof of delivery, successful installations and satisfactory performance (i.e. delivery challan and appropriate certificates duly signed by representative of purchaser). However, any delay in payments will not entitle the contractor for any compensation or interest or form ground for extension in delivery period without Liquidated Damages (LD).
- c) The currency or currencies in which payments shall be made to the Supplier under this Contract shall be Indian Rupees (INR) only.
- d) All remittance charges will be borne by the bidder.
- e) The payment shall be made by the purchaser only after the suppliers/contractors have delivered the products or services in full quantities ordered and obtained a certificate of successful installation and satisfactory performance from each user. The Service Provider has to ensure proper hand holding of the system.
- f) However, in exceptional cases (e.g. the supply is to be made over a long period of time and the products ordered has been partially supplied and installed or after partial fulfillment of the purchaser's order, the supplier is asked to delay remaining supplies or the installation is delayed due to non-readiness of the site etc.) the purchaser may make part payments.
- g) No advance payments will be made to any firm.
- h) Amount payable to the Service Provider as stated in the Contract shall remain non-negotiable and fixed during the tenure of the Contract.
- i) Application Software Services:
  - Payment of 50% of total cost after security audit and implementation of application software
  - 50% payment shall be made after one month after implementation of application software at NIELIT HQ & NIELIT Centre.
- j) Hardware Devices:
  - 40% total cost of hardware shall be made on supply and installation of hardware devices.
  - 60% payment shall be made one month after successful installation and integration of hardware devices.

### **13) Recoveries from Suppliers/ Bidders**

- a) Recovery of liquidated damages/ deductions for delay, short supply, breakage, rejected articles/ products shall be made from bills and/or on first available opportunity.
- b) The Purchase Officer shall withhold amount to the extent of short supply, broken/ damaged or for rejected articles/ products unless these are replaced satisfactorily. In case of failure to withhold the amount, it shall be recovered from any other dues of the supplier and performance security deposit submitted by the supplier.
- c) The balance, if any, shall be demanded from the Supplier/ Bidder and non-compliance of such demand shall be treated as breach of contract.

**14) Taxes & Duties**

- a) All Central/State Govt. /Local Body Levies as applicable from time to time shall be deducted at source from the payment to the Supplier/ Bidder as per the respective law in force at the time of execution of contract/release of payment.
- b) For goods/ products supplied from outside India, the Supplier shall be entirely responsible for all taxes, stamp duties, license fees, and other such levies imposed outside the country.
- c) For goods/ products supplied from within India, the Supplier shall be entirely responsible for all taxes, duties, license fees, etc., incurred until delivery of the contracted Goods to the Purchaser.
- d) If any tax exemptions, reductions, allowances or privileges may be available to the Supplier in India, the Purchaser shall provide appropriate help (e.g. bonafide documents etc.) to enable the Supplier to get the benefit from such exemption/privileges to the maximum allowable extent.

**15) Earnest Money Deposit (EMD)**

- a) The Bidders will be required to submit the EMD along with the technical bid.
- b) The EMD will be submitted through a Demand Draft (DD)/Banker Cheque (BC) drawn on any commercial bank in favour of NIELIT, payable at New Delhi.

**Forfeiture of EMD:** The EMD will be forfeited:

- If the bidder withdraws the bid after quoting and submission / acceptance;
- If the bidder withdraws the bid before the expiry of the validity period of 180 days of the bid or within the time frame of extension given by NIELIT in special case communicated before the expiry for the bid;
- If the bidder fails to comply with any of the provisions of the terms and conditions of the bid specification;
- If the selected bidder fails to execute agreement in prescribed format and submit the Performance Security.

**Refund of EMD**

- EMD shall be refunded to the selected bidder, only after signing of the contract after furnishing of performance guarantee by way of Bank Guarantee as mentioned below in section Performance Security Deposit.
- EMD of unsuccessful bidders will be refunded, without any interest, after the tender finalization or expiry of the tender validity, whichever is earlier, by Cheque after intimating them about the rejection of their tender bid.
- No interest will be payable on the amount of EMD.

**16) Performance Security Deposit**

- a) The successful Supplier/ Bidder shall, within fifteen (15) days of the notification of Contract award, provide a Performance Security deposit for an amount of 10% of the value of the awarded contract.
- b) The proceeds of the Performance Security deposit shall be payable to the Purchaser as compensation for any loss (including loss of opportunity, time or cost) resulting from the Supplier's/ Bidder's failure to comply with its obligations under the Contract.
- c) Form of Performance Security deposit: Security Deposit in the form of cash will not be accepted. Performance Security may be furnished in the form of an Account payee

Demand Draft, Fixed Deposit Receipt from a Commercial bank, Bank Guarantee from a Commercial bank in favour of NIELIT, payable at New Delhi. Bank Guarantee/FDR should be valid for a period of

- d) Refund of Performance Security Deposit: The Performance Security deposit shall be refunded after two months of the expiry of guarantee/ warranty period.
- e) Forfeiture of Performance Security deposit: Performance Security deposit shall be forfeited/invoked in the following cases: -
  - i. When any terms and condition of the contract is breached by the vendor/service provider.
  - ii. When the Supplier/ Bidder fails to commence supply or stops making the supplies or fail to provide deliverables after partially executing the purchase/ work order.
  - iii. When the equipments supplied/application software installed does not perform to the purchaser's expectation and the supplier does not or is not able to set right the equipment or in case of services, the supplier/contractor fails to fulfill its obligation under the contract.
- f) No interest will be paid by NIELIT on the amount of earnest money and performance security deposit.
- g) Proper notice will be given to the Supplier/ Bidder with reasonable time before earnest money/ performance security deposit is forfeited.
- h) Forfeiture of earnest money / performance security deposit shall be without prejudice to any other right of NIELIT to claim any damages as admissible under the law as well as to take such action against the Supplier/ Bidder such as severing future business relation or black listing, etc, as may be deemed fit.

### 17) Copyright

The copyright in all drawings, documents, and other materials containing data and information furnished to the Purchaser by the Supplier/ Bidder herein shall remain vested in the Supplier/ Bidder, or, if they are furnished to the Purchaser directly or through the Supplier/ Bidder by any third party, including suppliers of materials, the copyright in such materials shall remain vested in such third party.

### 18) Confidentiality: (Non-Disclosure Agreement)

- a) The Purchaser and the Supplier/ Bidder shall keep confidential and shall not, without the written consent of the other party hereto, divulge to any third party any documents, data, or other information furnished directly or indirectly by the other party hereto in connection with the Contract, whether such information has been furnished prior to, during or following completion or termination of the Contract.
- b) The Purchaser shall not use such documents, data, and other information received from the Supplier/ Bidder for any purposes not related to the Contract. Similarly, the Supplier/ Bidder shall not use such documents, data, and other information received from the Purchaser for any purpose other than the design, procurement, or other work and services required for the performance of the Contract.
- c) The obligation of a party under sub-clauses above, however, shall not apply to information that: -
  - i. the Supplier need to share with NIELIT or other institutions participating in the Contract;

- ii. now or hereafter enters the public domain through no fault of that party;
  - iii. can be proven to have been possessed by that party at the time of disclosure and which was not previously obtained, directly or indirectly, from the other party; or
  - iv. Otherwise lawfully becomes available to that party from a third party that has no obligation of confidentiality.
- d) The above provisions shall not in any way modify any undertaking of confidentiality given by either of the parties hereto prior to the date of the Contract in respect of the supply or any part thereof.
- e) The provisions of this clause shall survive completion or termination, for whatever reason, of the Contract.

### **19) Sub-contracting**

- a) Unless otherwise specified in the Contract, the bidder shall not assign or sub-let his contract or any substantial part thereof to any other agency without the permission of Purchasing Authority.
- b) If permitted, the bidder shall notify the Purchaser in writing of all subcontracts awarded under the Contract if not already specified in the Bid. Subcontracting shall in no event relieve the Supplier from any of its obligations, duties, responsibilities, or liability under the Contract.
- c) Subcontracts shall comply with the provisions of bidding document and/ or contract.

### **20) Specifications and Standards**

- a) All articles supplied shall strictly conform to the specifications, trademark laid down in the tender form and wherever articles have been required according to ISI/ ISO/ other applicable specifications/ certifications/ standards, those articles should conform strictly to those specifications/ certifications/ standards. The supply shall be of best quality and description. The decision of the competent authority/ purchase committee whether the articles supplied conforms to the specifications shall be final and binding.
- b) Technical Specifications and Drawings
  - i. The Supplier/ Bidder shall ensure that the products and related services comply with the technical specifications and other provisions of the Contract.
  - ii. The Supplier/ Bidder shall be entitled to disclaim responsibility for any design, data, drawing, specification or other document, or any modification thereof provided or designed by or on behalf of the Purchaser, by giving a notice of such disclaimer to the Purchaser.
  - iii. The products and related services supplied under this Contract shall conform to the standards mentioned in bidding document and, when no applicable standard is mentioned, the standard shall be equivalent or superior to the official standards whose application is appropriate to the country of origin of the Products.
- c) Wherever references are made in the Contract to codes and standards in accordance with which it shall be executed, the edition or the revised version of such codes and standards shall be those specified in the bidding document. During Contract execution, any changes in any such codes and standards shall be applied only after approval by the Purchaser and shall be treated in accordance with the general conditions of the contract.



**21) Software Services and License Agreements**

The licenses of all software(s) to be deployed as part of the project would be in the name of NIELIT and the original copy of the same shall be deposited by the successful Bidder at the office of NIELIT HQ/ as Applicable after signing of the contract and before the installation of the software at any of the sites.

**22) Product Upgrades**

At any point during performance of the Contract, shall technological advances be introduced by the Bidder and the company who owns the patent of the technology being offered. The IT Services originally offered by the Bidder in its bid and still to be delivered, the Bidder shall be obligated to offer to the Client the latest versions of the available information technologies having equal or better performance or functionality at the same or lesser unit prices.

**23) Project Planning and Performance**

- a) The agreed and finalized Project Plan will be prepared by the Bidder and approved by the Client/NIELIT in consonance with the partner. If required, the impact on the Implementation Schedule of modifications agreed during finalization of the agreed and finalized Project Plan shall be incorporated in the Contract by amendment.
- b) Bidder shall undertake to supply, install, test, and commission the Services in accordance with the agreed and finalized Project Plan both at NIELIT HQ & its offices.
- c) The progress report and other reports shall be prepared by the Partner/ Bidder and submitted to the Client in the format and frequency specified.
- d) If at any time the Bidder's actual progress falls behind the project schedule described in the agreed and finalized Project Plan, or it becomes apparent that it will so fall behind, the Bidder shall, at the request of the Client's Competent Authority /Officer, prepare and submit to the Competent Authority /Officer, a revised project schedule, taking into account the prevailing circumstances, and shall notify the Competent Authority /Officer of the steps being taken to expedite progress so as to attain completion of the facilities within the stated time for completion subsequent to the acceptance of the same at the partner level.
- e) NIELIT, as per rules, through its officials can undertake audit of the information provided by the bidder at any point of time. The bidder must provide support and access to the data and its offices meant for the project. In case of any dispute, NIELIT's decision will be final and binding on the bidder.
- f) In case NIELIT through audit or otherwise finds that the bidder has purposefully committed any irregularity, NIELIT has the right to terminate the contract to the cost of bidder with immediate effect.

**24) Inspection**

- a) NIELIT and/or its representative reserve the right of inspection of processes being followed by the Bidder anytime during the period of the contract. NIELIT reserves the right to inspect, test and, wherever necessary, reject the hardware delivered at Project Site. This shall in no way be limited or waived by reason of the Hardware having previously been inspected, tested and passed by NIELIT or its representative prior to the Hardware shipment.

- b) The supplier shall furnish complete address of the premises of his factory, office, go-down and workshop where inspection can be made together with name and address of the person who is to be contacted for the purpose. In case of those dealers who have newly entered in business, a letter of introduction from their bankers will be necessary.
- c) After successful inspection it will be supplier's responsibility to dispatch and install the equipment/ product at respective locations without any financial liability to the Purchaser. However, supplies when received at respective locations shall be subject to inspection to ensure whether they conform to the required specification.

## 25) Rejection

- g) Supplies/Services not approved during inspection or testing shall be rejected and will have to be replaced by the bidder at his own cost within the time fixed by the Purchase Officer.
- h) If, however, due to exigencies of NIELIT's work, such replacement either in whole or in part, is not considered feasible, the Purchase Officer after giving an opportunity to the bidder of being heard shall for reasons to be recorded, deduct a suitable amount from the approved rates. The deduction so made shall be final.
- i) The rejected supplies shall be removed by the bidder within 15 days of intimation of rejection, after which Purchase Officer shall not be responsible for any loss, storage or damage and shall have the right to dispose of such articles as he thinks fit, at the bidder's risk and on his account.

## 26) Commissioning and Operational Acceptance

- a) Commissioning of the Project shall be commenced by the Bidder and the company who owns the patent of the technology being offered immediately after intimation of acceptance is issued by the Client's Representative.
- b) The Client shall supply the operating and technical personnel and all materials and information reasonably required to enable the Bidder to carry out its obligations with respect to Commissioning of project.
- c) Production use of the IT or Services shall not commence prior to the start of the formal Operational Acceptance Testing.
- d) The Operational Acceptance Tests shall be the primary responsibility of the Client, but shall be conducted with the full cooperation of the Bidder and the company who owns the patent of the technology being offered, during Commissioning of the IT Application to ascertain whether they conform to the requirements and meets the standard of performance quoted in the Bidder's bid, including, but not restricted to, the functional and technical performance requirements.
- e) If, for reason attributable to the Client, the Operational Acceptance Test of the IT Application cannot be successfully completed within the period specified, from the date of Installation or any other period agreed upon in writing by the Client and the Bidder, the Bidder and the company who owns the patent of the technology being offered shall be deemed to have fulfilled its obligations with respect to the technical and functional aspects.
- f) If the IT Application fails to pass the Operational Acceptance Test(s) then the Client may consider terminating the Contract to the risk and cost of Bidder.

**27) Completion Time Guarantee**

The Bidder and the company who owns the patent of the technology being offered shall guarantee that it shall complete the Commissioning of project within the time periods specified in the Implementation Schedule and/or Agreed and Finalized Project Plan or within such extended time to which the Bidder shall be entitled to.

**28) Defect Liability**

- a) The Bidder and the company who owns the patent of the technology being offered shall give a warrant that all Services/Products to be delivered under this contract:
- shall be free from defects in the design and workmanship;
  - are newly manufactured, unused, and incorporate all recent material improvements in design; and
  - complies with or exceeds the Technical Specifications
  - Commercial warranty provisions of products supplied under the Contract shall apply to the extent that they do not conflict with the provisions of this Contract.
- b) In addition, the Bidder and the company who owns the patent of the technology being offered shall warrant that:
- The Warranty Period shall commence from the date of Operational Acceptance of the IT Services.
  - If during the Warranty Period any defect is found in the design, documentation, and workmanship of the Product/Services provided by the Bidder , the Bidder and the company who owns the patent of the technology being offered shall promptly, in consultation and agreement with the Client regarding appropriate remedying of the defects, and at its sole cost, repair, replace, or otherwise make good (as the Bidder shall, at its discretion, determine) such defect as well as any damage to the Products and/or Services caused by such defect.

**29) Functional Guarantees**

- The Bidder and the company who owns the patent of the technology being offered shall guarantee that during the Operational Acceptance, the IT Services shall attain the Functional Guarantees, subject to and upon the conditions therein specified.
- a) If, for reasons attributable to the Bidder, the minimum level of the Functional Guarantees is not met either in whole or in part, the Bidder and the company who owns the patent of the technology being offered shall at their own cost and expense make such changes, modifications and/or additions to the Services or any part thereof as may be necessary to meet at least the minimum level of such Guarantees.
- b) The Bidder and the company who owns the patent of the technology being offered shall notify the Client upon completion of the necessary changes, modifications and/or additions, and shall request the Client to repeat the Operational Acceptance Test until the minimum level of the Guarantees has been met.
- c) If the Bidder and the company who owns the patent of the technology being offered eventually fails to meet the minimum level of Functional Guarantees, the Client may consider termination of the Contract to the risk and cost of Bidder.

**30) Warranty**

- a) The Supplier shall represent and warrant that

- Services/Products as supplied are free from defects arising from any act or omission of the Supplier or arising from design, materials, and workmanship, under normal use in the conditions prevailing in the place of final destination.
  - The Services/Products supplied/installed have been tested and accepted.
  - Use of the Services/Products in accordance with the Contract;
  - Copying of the Software and Documentation provided in accordance with the Contract do not and will not infringe any IPR held by any third party and that it has all necessary rights or at its sole expense shall have secured in writing all transfers of rights and other consents necessary to make the assignments, licenses, and other transfers of IPR and the warranties set forth in the Contract.
  - Without limitation, the Bidder shall secure all necessary written agreements, consents, and transfers of rights from its employees and other persons or entities whose services are used for Project execution.
  - The Bidder shall pass on the warranty or benefits provided by the third party owner of the product in favor of NIELIT.
- b) Unless otherwise specified in the bidding document and/ or contract, the comprehensive on-site warranty shall remain valid for a minimum period of one year after the Services/Products, or any portion thereof as the case may be, have been delivered to and accepted at the final destination indicated in the Purchase/work order. The warranty on software media should be at least one year .
- c) The bidder would give comprehensive onsite warranty/ guarantee that the products/ services/ articles including machinery and equipment would continue to conform to the description and quality as specified for the period as mentioned the clauses above from the date of delivery & installation of the said products/ services. The purchaser will be entitled to reject the said products/ services or such portion thereof as may be found deficient/ non-conforming to the said description and quality. On such rejection the products/ articles/ services will be at the supplier's risk and all the provisions relating to rejection of products etc., shall apply. The supplier shall if so called upon to do, replace the products etc., or such portion thereof as is rejected by Purchase Officer, otherwise the supplier shall pay such damages as may arise by the reason of the breach of the condition herein contained. Nothing herein contained shall prejudice any other right of the Purchase Officer in that behalf under this contract or otherwise.
- d) The warranty of the supplies covered under one Purchase Order (PO) shall start from the date of last successful installation of the items covered under the PO or one month from the last due date of completion of installation, whichever is earlier. However, if delay of installation is more than a month's time due to the firm's own reasons, the warranty shall start from the date of last successful installation of the items covered under the PO. The firm, if facing any problem in installation, will immediately inform NIELIT in writing to resolve the issue.
- e) The Purchaser shall give Notice to the Supplier stating the nature of any such defects together with all available evidence thereof, promptly following the discovery thereof. The Purchaser shall afford all reasonable opportunity for the Supplier to inspect such defects.
- f) Upon receipt of such Notice, the Supplier shall, within the period specified, expeditiously repair or replace the defective supplies or parts thereof, at no cost to the Purchaser.

- g) If having been notified, the Supplier fails to remedy the defect within the period specified, the Purchaser may proceed to take within a reasonable period such remedial action as may be necessary, at the Supplier's risk and expense and without prejudice to any other rights which the Purchaser may have against the Supplier under the Contract.

### **31) Extension in Delivery Period and Liquidated Damages (LD)**

- a) Except as provided under clause "Force Majeure", if the Supplier/ Bidder fails to deliver any or all of the Products or perform the Related Services within the period specified in the Contract, the Purchaser may without prejudice to all its other remedies under the Contract, deduct from the Contract Price, as liquidated damages.
- b) The time specified for delivery in the RFP shall be deemed to be the essence of the contract and the successful bidder shall arrange supplies within the specified period.
- c) Delivery and installation/ completion period may be extended with or without liquidated damages if the delay in the supply of products or service is on account of hindrances beyond the control of the bidder.
- i. The supplier/ service provider shall request in writing to NIELIT giving reasons for extending the delivery period of service if he finds himself unable to complete the supply of products or service within the stipulated delivery period or is unable to maintain prorate progress in the supply of products or service delivery. This request shall be submitted as soon as a hindrance in delivery of products and service occurs or within 15 days from such occurrence but before expiry of stipulated period of completion of delivery of products and service after which such request shall not be entertained.
  - ii. NIELIT shall examine the justification of causes of hindrance in the delivery of products and service and the period of delay occurred due to that and take appropriate decision on the period of extension which should be granted with or without liquidated damages.
  - iii. Normally, extension in delivery period of products and service in following circumstances may be considered without liquidated damages:
    - a. When delay has occurred due to delay in supply of drawings, designs, plans, communication of approvals/acceptances etc. which NIELIT was required to supply to the supplier of products or service provider as per terms of the contract.
    - b. When delay has occurred in supply of materials etc. which were required to be supplied to the supplier or service provider by the NIELIT as per terms of the contract.
  - iv. If NIELIT agrees to extend the delivery period/ schedule, an amendment to the contract with suitable denial clauses and with or without liquidated damages, as the case may be, shall be issued. The amendment letter shall specifically mention that no extra price or additional cost for any reason, what so ever beyond the contracted cost shall be paid for the delayed supply of products and service.
  - v. It shall be at the discretion of the concerned authority to accept or not to accept the supply of products and/ or services rendered by the contractor after the expiry of the stipulated delivery period, if no formal extension in delivery period has been applied and granted. The competent authority shall have right to cancel the contract with respect to undelivered products and/ or service.

- vi. If NIELIT accepts the products and/ or services after expiry of the stipulated delivery period, it may accept the services and issue a letter of extension in delivery period with usual liquidated damages and denial clauses to regularize the transaction.
- d) In case of extension in the delivery and/ or installation/ completion period is granted with full liquidated damages, the recovery shall be made on the basis of following percentages of value of products and/ or service which the bidder has failed to supply or complete : -

**Note:Completion of work=>software implementation and hardware installation at each office**

S. No.	Condition	LD %
a.	Delay up to 20 days of the prescribed period of delivery, successful installation and completion of work	2.5 %
b.	Delay between 20-30 days of the prescribed period of delivery, successful installation and completion of work	5.0 %
c.	Delay between 30-40 days of the prescribed period of delivery, successful installation and completion of work	7.5 %
d.	Delay between 40-50 days of the prescribed period of delivery, successful installation and completion of work	10.0 %
e.	Delay more than 50 days	Termination of Contract

**LD% - LD in terms of percentage of the value of WORKS/SERVICES delayed.**

- Fraction of a day in reckoning period of delay in supplies, successful installation and completion of work shall be ignored if it is less than half a day.
- The value of stores and/ or services not received in prescribed time should be calculated carefully. The method of calculation for contracts which include multiple items of supply/ service in case individual value of each item is not taken in the tender should be generally given in the tender document and/ or the contract/ agreement. For example, in a contract to supply, install and commission the equipment, the equipment may be supplied in time but may not be commissioned in time. How the apportionment of the total value of the contract will be done into value of the supplied equipment and the value of installation and commissioning should be mentioned in the contract. If not mentioned specifically, the total cost of supply and commissioning should be taken for imposing damages.
- For turnkey projects in which cost of individual items is not known also, some apportionment formula should be given in the contract. If not given, the total value of the turnkey project shall become the basis for imposing LD, if due.
- Similarly, care needs to be taken in calculating the value of services not delivered in time in case of services of continuing nature, for example, FMS or providing services of consultants/ professionals. In such cases, the value of services for the period of delay can be taken as the value of services delayed. To illustrate this, if a consultant with a man month rate of Rs. 1 lakh per month is placed with a delay of two months, the value of services on which LD will be imposed as per table given above will be Rs. 2 Lakhs.
- The maximum amount of liquidated damages shall be 10% of contract price subject to above clauses.

**32) Patent Indemnity**

a) The Supplier shall, subject to the Purchaser's compliance with sub-clause (b) below, indemnify and hold harmless the Purchaser and its employees and officers from and against any and all suits, actions or administrative proceedings, claims, demands, losses, damages, costs, and expenses of any nature, including attorney's fees and expenses, which the Purchaser may suffer as a result of any infringement or alleged infringement of any patent, utility model, registered design, trademark, copyright, or other intellectual property right registered or otherwise existing at the date of the Contract by reason of the installation of the Products by the Supplier or the use of the Products in the NIELIT Offices.

Such indemnity shall not cover any use of the Products or any part thereof other than for the purpose indicated by or to be reasonably inferred from the Contract, neither any infringement resulting from the use of the Products or any part thereof, or any products produced thereby in association or combination with any other equipment, plant, or materials not supplied by the Supplier, pursuant to the Contract.

b) If any proceedings are brought or any claim is made against the Purchaser out of the matters referred to above, the Purchaser shall promptly give the Supplier a notice thereof, and the Supplier shall at its own expense and in the Purchaser's name conduct such proceedings or claim and any negotiations for the settlement of any such proceedings or claim.

c) If the Supplier fails to notify the Purchaser within thirty (30) days after receipt of such notice that it intends to conduct any such proceedings or claim, then the Purchaser shall be free to conduct the same to the cost of supplier.

d) The Purchaser shall, at the Supplier's request, afford all available assistance to the Supplier in conducting such proceedings or claim, and shall be reimbursed by the Supplier for all reasonable expenses incurred in so doing.

**33) Limitation of Liability**

Except in cases of negligence or willful misconduct: -

a) Neither Party shall be liable to the other Party, whether in contract, tort, or otherwise, for any indirect or consequential loss or damage, loss of use, loss of production, or loss of profits or interest costs, which may be suffered by the other Party in connection with the Contract,, provided that this exclusion shall not apply to any obligation of the Supplier to pay liquidated damages to the Purchaser; and

b) the aggregate liability of the Supplier to the Purchaser, whether under the Contract, in tort, or otherwise, shall not exceed the amount specified in the Contract, provided that this limitation shall not apply to the cost of repairing or replacing defective equipment, or to any obligation of the Supplier to indemnify the Purchaser with respect to patent infringement.

**34) Criminal Charges and Conviction**

The Bidder warrants that it has disclosed and will continue to disclose during the term of this Contract full details of all criminal convictions and all pending criminal charges against it or any of its personnel and associates that would reasonably be expected to adversely affect the Bidder and the company who owns the patent of the technology being offered or the Bidder's capacity to fulfill its obligations under this contract.

### 35) Change in Laws & Regulations

If after the date of bid submission, any law, regulation, ordinance, order or by-law having the force of law is enacted, promulgated, abrogated or changed which shall be deemed to include any change in interpretation or application by the competent authorities, that subsequently affects the costs and expenses of the Bidder and/or the Time for Completion, the Contract Price shall be correspondingly increased or decreased, and/or the Time for Completion shall be reasonably adjusted to the extent that the Bidder has thereby been affected in the performance of any of its obligations under the Contract.

### 36) Force Majeure

- a) The Supplier shall not be liable for forfeiture of its Performance Security deposit, liquidated damages, or termination for default if and to the extent that its delay in performance or other failure to perform its obligations under the Contract is the result of an event of Force Majeure.
- b) For purposes of this Clause, “Force Majeure” means an event or situation beyond the control of the Supplier that is not foreseeable, is unavoidable, and its origin is not due to negligence or lack of care on the part of the Supplier. Such events may include, but not be limited to, acts of the Purchaser in its sovereign capacity, wars or revolutions, fires, floods, epidemics, quarantine restrictions, riots/law and order embargoes and freight embargoes.
- c) If a Force Majeure situation arises, the supplier shall promptly notify the purchaser in writing of such conditions and cause thereof within 15 days of occurrence of such event. Unless otherwise directed by NIELIT, the supplier shall continue to perform its obligations under the contract as far as reasonably practical.
- d) If the performance in whole or part or any obligation under the contract is prevented or delayed by any reason of Force Majeure for a period exceeding 60 days, either party at its option may terminate the contract without any financial repercussion on either side.
- e) In case a Force Majeure situation occurs with the NIELIT, the NIELIT may take the case with the contractor on similar lines.

### 37) Compliance with Laws

- The Bidder and the company who owns the patent of the technology being offered shall undertake to observe, adhere to, comply with and notify NIELIT about all laws in force or as are made applicable in future, pertaining to or applicable to the Bidder’s business, their employees or their obligations towards employees and all purposes of this tender and shall indemnify, keep indemnified, hold harmless, defend and protect NIELIT and its employees/officers/staff/ personnel/representatives/agents from any failure or omission on its part to do so and against all claims or demands of liability and all consequences that may occur or arise for any default or failure on its part to conform or comply with the above and all other statutory obligations arising there from.
- The Bidder and the company who owns the patent of the technology being offered shall promptly and timely obtain all such consents, permissions, approvals, licenses, etc, as may be necessary or required for any of the purposes of this project or for the conduct of their own business under any applicable Law, Government Regulation and shall keep the same valid and in force during the term of the project, and in the event of any failure or omission to do so, shall indemnify, keep indemnified, hold harmless, defend, protect and



fully compensate NIELIT and its employees/ officers/ staff/ personnel/ representatives/agents from and against all claims or demands of liability and all consequences that may occur or arise for any default or failure on its part to conform or comply with the above and all other statutory obligations arising there from and NIELIT shall give notice of any such claim or demand of liability within reasonable time to the Bidder.

- The Bidder agrees that the Bidder shall not be entitled to assign / sub lease any or all of its rights and or obligations under this tender and subsequent Agreement to any entity including Bidder's affiliate without the prior written consent of NIELIT.

### **38) Change Orders and Contract Amendments**

- a) The Purchaser may at any time order the Supplier/ Bidder through Notice in accordance with clause "Notices" above, to make minor changes within the general scope of the Contract in any one or more of the following: -
  - i. drawings, designs, or specifications, where Products to be furnished under the Contract are to be specifically manufactured for the Purchaser;
  - ii. the method of shipment or packing;
  - iii. the place of delivery; and
  - iv. the Related Services to be provided by the Supplier.
- b) If any such change causes an increase or decrease in the cost of, or the time required for, the Supplier's/ Bidder's performance of any provisions under the Contract, an equitable adjustment shall be made in the Contract Price or in the Delivery and Completion Schedule, or both, and the Contract shall accordingly be amended. Any claims by the Supplier/ Bidder for adjustment under this clause must be asserted within thirty (30) days from the date of the Supplier's/ Bidder's receipt of the Purchaser's change order.
- c) Prices to be charged by the Supplier/ Bidder for any Related Services that might be needed but which were not included in the Contract shall be agreed upon in advance by the parties and shall not exceed the prevailing rates charged to other parties by the Supplier/ Bidder for similar services.

### **39) Termination**

#### **a) Termination for Default**

- i. The tender sanctioning authority of NIELIT may, without prejudice to any other remedy for breach of contract, by written notice of default sent to the contractor, terminate the contract in whole or in part if the contractor: -
  - a. has abandoned or repudiated the Contract; or
  - b. has without valid reason failed to commence work on the project promptly; or
  - c. Persistently fails to execute the Contract in accordance with the terms of contract or persistently neglects to carry out its obligations under the Contract without just cause; or
  - d. refuses or is unable to provide sufficient Documentation, Services, or labour to execute and complete the project in the manner specified in the agreed and finalized Project Plan; or
  - e. fails to deliver any or all quantities of the service within the time period specified in the contract, or any extension thereof granted by NIELIT; or

- f. fails to perform any obligation under the contract within the specified period of delivery of service or any extension granted thereof; or
- g. in the judgment of the Purchaser has engaged in corrupt, fraudulent, collusive, or coercive practices in competing for or in executing the contract.
- h. commits breach of any condition of the contract.
- ii. If NIELIT terminates the contract in whole or in part then amount of Performance Security Deposit (PSD) will be forfeited.

**b) Termination for Insolvency**

NIELIT may at any time terminate the Contract by giving Notice to the Supplier if the Supplier becomes bankrupt or otherwise insolvent. In such event, termination will be without compensation to the Supplier, provided that such termination will not prejudice or affect any right of action or remedy that has accrued or will accrue thereafter to NIELIT.

**c) Termination for Convenience**

- i. NIELIT, by Notice of, 30 Days, sent to the Supplier, may terminate the Contract, in whole or in part, at any time for its convenience. The Notice of termination shall specify that termination is for the Purchaser's convenience, the extent to which performance of the Supplier under the Contract is terminated, and the date upon which such termination becomes effective.
- ii. Depending on merits of the case the contractor may be appropriately compensated on mutually agreed terms for the loss incurred by the contract if any due to such termination.
- iii. The Products that are complete and ready for shipment within twenty-eight (28) days after the Supplier's receipt of the Notice of termination shall be accepted by the Purchaser at the Contract terms and prices. For the remaining Products, the Purchaser may elect:
  - a. To have any portion completed and delivered at the Contract terms and prices; and/or
  - b. To cancel the remainder and pay to the Supplier an agreed amount for partially completed Products and Related Services and for materials and parts previously procured by the Supplier.

#### **40) Disputes and Arbitration**

In the event of any disputes or differences arising out of or in any way relating to or concerning this contracts or effects of this contract, the same shall be referred to the sole arbitrator to be appointed by the Secretary, Department of Electronics & Information Technology, Government of India. The award of the arbitrator shall be final and binding on both the parties. The Delhi courts shall have jurisdiction for any disputes and the venue for arbitration shall be Delhi. Fee payable to the Arbitrator, to be shared equally by the parties shall be as per the Rules of The Indian Council of Arbitration in force at the time of appointment of Arbitrator.

**41) Special Terms & Conditions**

- a) Wherever applicable, the whole work will be conducted onshore through various technical staff including but not limited to resources posted at NIELIT/ designated project sites assisting NIELIT projects on product development, system design and training, etc.
- b) At the time of issuance of a work order, NIELIT may impose service level standards.
- c) The exact scope of work, deliverables, milestones and timelines shall be mutually decided later at an appropriate time looking to the requirements of the project. However, the decision of the tendering authority, in this regard, shall be final and binding upon the firm.

**Annexure I**

**Application Form**

**1. Addressed to:**

Authority	Managing Director
Address	NIELIT, Electronics Niketan Building, 6, CGO Complex, New Delhi – 110003, India.
Telephone	+91-11-24363330/1/2, 24366577/79/80
Tele Fax	+91 11 24363335
Email	tender@nielit.in

**2. Ref Number:** 60(4)2013.NIELIT-HQ

**3. Firms Particulars:**

Name of Firm	
Name of Contact Person with Designation	
Registered Office Address	
Details of Incorporation of the Company. Certificate to be submitted in Technical bid	Date:
	Ref #
Details of Commencement of Business	Date:
	Ref#
Valid VAT/Sales Tax Registration no.	
Valid Service Tax Registration no.	
Permanent Account Number (PAN)	

Address of the Firm				
Type of Firm	Public Limited	Private Limited	Partnership	Proprietary
Put Tick(√) mark				
Telephone/Mobile Number(s)				
Email Address				
Website URL				
Fax No.				
Certification/Accreditation/Affiliation, if Any (attach proof)				
Quality Certification(attach proof)				

#### 4. Financial Status for last 3 years (or since incorporation)

As per audited Balance Sheets (in Cr)				
Sno	Year	2009-10	2010-11	2011-12
1	Net worth			
2	Turn Over			
3	Profit After Tax			

#### 5. Deposit of Tender Document Fees and EMD (in favour of NIELIT, payable AT at New Delhi)

Description	Number	Dated	Amount	Drawee Bank & Branch
Demand Draft / Banker's Cheque				

6. Financial Bid given in this Tender Document is enclosed in a separate envelope duly signed and sealed.

We confirm that a) we own / are authorized by parent companies for the IPR of those parts of the software that are developed by us and b) we have the permission to use third party components of the software from the respective manufactures for the NIELIT BAS. c) We understand that wherever third party component e.g. Software/Technology involving IPR issues is used by our organization, necessary license/permission shall be obtained by us in favour of NIELIT. d) We accept all terms and conditions mentioned in this RFP. e) We understand that NIELIT is not bound to accept the offer and that NIELIT has the right to reject the offer without assigning any reasons whatsoever.

Yours faithfully,

Authorized Signatory of Prime Bidder (Name and Designation)

Seal of the firm:

Place: \_\_\_\_\_

Date: \_\_\_\_\_

**Annexure II**

Letter of undertaking  
(ON THE LETTER HEAD OF THE APPLICANT)

To

The Managing Director  
National Institute of Electronics and Information Technology (NIELIT),  
Electronics Niketan, 6, CGO Complex, Lodhi Road,  
New Delhi - 110 003, India

Subject: RFP for Web based Biometric Attendance System (BAS) FOR NIELIT

Dear Sir,

This bears reference to NIELIT \_\_\_\_\_. We, hereby, accept all the terms and conditions for submitting bid as mentioned in this RFP document.

We hereby certify that no terms and conditions have been stipulated by us in the submitted Bid. We warrant that services provided by us do not violate or infringe upon any patent, copyright, trade secret or other property right of any other person or other entity. We agree that we shall prevent NIELIT from any claim or demand, action or proceeding, directly or indirectly resulting from or arising out of the contract on this account.

The above document is executed on \_\_\_/\_\_\_/2013 at (place) \_\_\_\_\_ and we accept that if anything out of the information provided by us is found wrong our work order shall be liable for rejection.

Yours faithfully,

Signature:

Name: \_\_\_\_\_

Designation: \_\_\_\_\_

Place: \_\_\_\_\_

Date: \_\_\_\_\_

**Annexure III**

**Financial Bid (RFP for NIELIT BAS)**

Name of the Bidder: \_\_\_\_\_

Address for Correspondence: \_\_\_\_\_  
 \_\_\_\_\_  
 \_\_\_\_\_

S.No	Description	Cost	Total Amt. Excl. of taxes (In Rs)	Tax, if any
1.	<b>Application Software</b>			
	Designing, Developing, Testing, Training, Implementation of Web based Biometric Attendance System			
2.	<b>Hardware</b>			
	Supply and installation of Biometric Attendance Device (LAN based)			
3.	<b>Warranty for one year</b>			
4.	<b>Charges (per annum) for AMC of Hardware and Software</b>			

Note:

1. The rate should not be provided as a percentage figure.
2. The Bidder is advised to quote rate in absolute Indian Rupees.
3. The rate quoted will be valid for period of contract from the date of opening of technical bid. The period can be extended with mutual agreement.
4. No condition will be entertained and conditional Bid will be liable to be rejected.
5. All details should be clearly mentioned without any cut / marks and should be legible preferably in bold black ink.
6. Bidder is further required to submit a detailed item wise breakup. (Training per centre including transportation, lodging for one/two persons, Hardware supply at each office etc.)

Signature and Seal of Bidder

Name: \_\_\_\_\_



**Annexure IV**

**Format for providing CVs for Project Manager, Team Leader and Team Members**

1. **Position:**

2. **Name of Firm:**

3. **Name of Staff:**

4. **Date of Birth:**

5. **Nationality:**

6. **Education:**

*Indicate college/university and other specialized education of staff member, giving names of institutions, degrees obtained:*

Degree /Stream	University/ Institution	Year in which obtained

7. **Membership of Professional Associations:**

8. **Other Trainings:**

9. **Countries of Work Experience:** List countries where staff has worked in the last ten years

14. **Languages:** For each language indicate proficiency: good, fair, or poor in speaking, reading, and writing

Language	Speaking	Reading	Writing

11. **Employment Record:** *Starting with present position, list in reverse order every employment held by staff member since graduation, giving for each employment (see format here below): dates of employment, name of employing organization, positions held*

From:	To:
Employer	

12. **Detailed Tasks Assigned:** *List all tasks to be performed under this Assignment/job*

**13. Work Undertaken that Best illustrates the experience as required for the Role**

*Among the Assignment/jobs in which the staff has been involved, indicate the following information for those Assignment/ jobs that best illustrate staff capability to handle the tasks listed under point 12.*

<b>Name of assignment/job or project</b>	
<b>Name of the client</b>	
<b>Year</b>	
<b>Location</b>	
<b>Main Project Features</b>	
<b>Position Held</b>	
<b>Activities performed</b>	

14. I, the undersigned, certify that to the best of my knowledge and belief, this CV correctly describes me, my qualifications, and my experience. I understand that any willful misstatement described herein may lead to my disqualification or dismissal, if engaged.

Date:

Place:

\_\_\_\_\_  
*[Signature of staff member or authorized representative of the staff]*

Full name of authorized representative:

**Annexure V****SELF-DECLARATION – NO BLACKLISTING**

To

The Managing Director

National Institute of Electronics and Information Technology (NIELIT),

Electronics Niketan, 6, CGO Complex, Lodhi Road,

New Delhi - 110 003, India

In response to this RFP document pertaining to NIELIT BAS, I/ We hereby declare that presently our Company/ firm \_\_\_\_\_ is having unblemished record and is not declared ineligible for corrupt and /or fraudulent practices either indefinitely or for a particular period of time by any State/ Central Government/ PSU/Autonomous Body.

We further declare that presently our Company/ firm \_\_\_\_\_ is not blacklisted and not declared ineligible for reasons other than corrupt & fraudulent practices by any State/ Central Government/ PSU/ Autonomous Body on the date of Bid Submission.

If this declaration is found to be incorrect then without prejudice to any other action that may be taken, my/ our security may be forfeited in full and the award of work contract if any to the extent accepted may be cancelled.

Thanking you,

Name of the Bidder: -

Authorized Signatory: -

Seal of the Organization: -

Date:

Place:

**Annexure VI****Format Power of Attorney**

(On Stamp paper of relevant value)

Know all men by the present, we \_\_\_\_\_ (name of the company and address of the registered office) do hereby appoint and authorize Mr \_\_\_\_\_ (full name and residential address) who is presently employed with us holding the position of \_\_\_\_\_ as our attorney, to do in our name and on our behalf, deed and things necessary in connection with or incidental to our bid in response to the RFP by NIELIT, including signing and submission of all the documents and providing information/responses to NIELIT in all the matter in connection with our bid.

We hereby agree to ratify all deeds and things lawfully done by our said attorney pursuant to this Power of Attorney and that all deeds and things done by our aforesaid attorney shall always be deemed to have been done by us.

Dated this \_\_\_\_\_ day of \_\_\_\_\_ 2013.

For \_\_\_\_\_.

(Signature)

(Name Designation and Address)

Accepted

Signature)

(Name Designation)

Date:

Business

Address:

Annexure VIIREPRESENTATIVE AUTHORIZATION LETTER

Date : \_\_\_\_\_

Ref : \_\_\_\_\_

To

The Managing Director

National Institute of Electronics and Information Technology (NIELIT),

Electronics Niketan, 6, CGO Complex, Lodhi Road,

New Delhi - 110 003, India

Dear Sir,

Ms. /Mr. \_\_\_\_\_ is hereby authorised to sign relevant documents on behalf of our organisation for the RFPs **for NIELIT BAS**. She/ He is also authorised to attend meetings & submit technical & financial information as may be required by you in the course of processing above said RFP.

Thanking you,

Authorised Signatory

Representative Signature

Company Seal

**Annexure VIII****BANK GUARANTEE**

To

National Institute of Electronics & Information Technology  
Electronics Niketan  
6, CGO Complex,  
New Delhi – 110 003

**Sub: Performance Guarantee for \_\_\_\_\_**

Dear Sir,

This Deed of Guarantee executed by the \_\_\_\_\_ (Bank name) a Scheduled Bank within the meaning of the Reserve Bank of India Act, 1934 and carrying out banking business including guarantee business and having its head office at \_\_\_\_\_ (hereinafter referred to as ‘the Bank’) in favour of NIELIT, an autonomous body of Department of Information Technology, Ministry of Communication & Information Technology Government of India and having its Registered office at Electronics Niketan, 6, CGO Complex, New Delhi – 110003 for supply of \_\_\_\_\_ (name(s) \_\_\_\_\_ (Rupees \_\_\_\_\_) (Approx. \_\_\_% of \_\_\_\_\_), being the total value of the items purchased including all taxes) after supply and installation of the items towards performance warrantee of the item (s) Supplied.

This Guarantee is issued subject to the condition that the liability of the bank under this guarantee is limited to a maximum of ` \_\_\_\_\_ (Rupees \_\_\_\_\_ only) and the Guarantee Shall remain in force upto \_\_\_\_\_ (\_\_\_\_\_ year from the date of Issue of this Bank Guarantee and cannot to invoked, otherwise than by a written demand or claim under this guarantee served on the Bank on or before \_\_\_\_\_ by the NIELIT, New Delhi.

And whereas the bank \_\_\_\_\_ (name and address) has agreed to give on behalf of the Supplier a Guarantee:

Therefore, we hereby affirm that we unconditionally Guarantee and are responsible to you on behalf of the Supplier, upto a total amount of-

\_\_\_\_\_ (Rupees-  
\_\_\_\_\_ only) and we undertake to pay you, at the very first instance without any demur upon your demand without cavil or argument, any sum or sums as specified by you within or upto the limit of \_\_\_\_\_ (Rupees-  
\_\_\_\_\_) i.e. the amount of bank guarantee as aforesaid, without your need to prove or to show grounds or reasons for your demand of the sum specified therein. This Guarantee shall not be affected by any change in the Constitution of the Bank or supplier or beneficiary.

**NOTWITHSTANDING ANYTHING CONTAINED HEREIN**

The bank hereby covenants and declares that the guarantee hereby given is an irrevocable on and shall not be revoked under any circumstances and/ or by a Notice or otherwise.

The Bank agrees that the amount hereby guaranteed shall be due and payable to NILEIT on serving us with a notice before expiry of Bank Guarantee requires the payment of the amount and such notice shall be deemed to have been served on the bank either by actual delivery thereof to the Bank by registered post at the address of the Bank.

This guarantee shall remain in force up to \_\_\_\_\_ provided that if so desired by NIELIT, this guarantee shall be renewed at the instance of supplier or NIELIT for a further period as may be indicated by them on the same terms and conditions as contained therein.

Dated at                      This                      Day of

SEALED & SIGNED BY THE BANK

Note: for information

1. The guarantee should be furnished by a Nationalized Bank/Scheduled Bank, authorized by RBI to issue a Bank Guarantee.
2. This bank guarantee should be furnished on stamp paper specified for the purpose.
3. The stamp paper should have been purchased in the Name of the Bank executing the Guarantee.

**Annexure IX**

**PRE-BID QUERIES FORMAT**

**Name of the Company/Firm:**

Tender Fee Receipt No. \_\_\_\_\_ Dated \_\_\_\_\_ for Rs. \_\_\_\_\_ /-

**Name of Person(s) Representing the Company/ Firm:**

Name of Person	Designation	Email-ID(s)	Tel. Nos. & Fax Nos.

**Company/Firm Contacts:**

Contact Person(s)	Address for Correspondence	Email-ID(s) Tel. Nos. & Fax Nos.

**Query / Clarification Sought:**

S.No.	RFP Page No.	RFP Rule No.	Rule Details	Query/ Suggestion/Clarification

**Note:** - Queries must be strictly submitted only in the prescribed format (.XLS/ .XLSX/ .ODF). Queries not submitted in the prescribed format will not be considered/ responded at all by the tendering authority. Also, kindly attach the coloured scanned copy of the receipt towards the submission of the bidding/ tender document fee.



**Annexure X****Proforma For Hardware/Software Requirement For Deployment of BAS**

For hosting of Application Software of BAS	1. 2. 3. 4. 5.
For Biometric Machines and Hardware Devices	1. 2. 3. 4. 5.
Integration and Implementation	1. 2. 3. 4. 5.

## Annexure-XI

## Minimum Technical Specification

Biometric Device for Web Based biometric attendance system		
Item	Description of Requirement	Compliance/ Deviations
Model Offered	Mention Make →	
Make Offered	Mention Model →	
Dimensions (W X L X H)	27 X 40 X 73 mm (without stand)	
Cable Length	Min 1800 mm	
Certification	FCC, CE	
Sensor	Optical	
Sensing Prism hardness	750 Hk (6.8 Mohs)	
Image Resolution	500 DPI	
Image Size	260 X 300 Pixels	
Platen Size	16.1 mm X 18.2 mm	
Image Grayscale	256 shades	
Image Type	Non lossy	
Distortion	<0.1 %	
Light Source	Red LED	
Lifetime (typical)	Min 60,000 hours	
Operating Voltage	5 V from USB port	
Supporting Operating System	Windows 98/Me/NT4/2000/XP/Vista/7 or Higher	
Interface	USB 2.0	
Communication speed (max)	12 Mbps	
Verification Time	Less than 1 Sec	
Latent Fingerprint Check Delay	0.01 sec	
Auto On Function	Yes	
Hardened Contact area	Yes	

**Annexure-XII**
**Employee Details - NIELIT HQ and Office/Centre**

S. No.	Office/Centre	Approx. NO. of Employee	Approx. # Device
1	Head quarters at New Delhi	76	4
2	Agartala	16	2
3	Aizawl	23	2
4	Ajmer	03	2
5	Aurangabad	37	3
6	Calicut	45	3
7	Chandigarh	208	9
8	Chennai	11	2
9	Delhi	20	2
10	Gangtok	03	2
11	Gorakhpur	42	3
12	Guwahati	19	2
13	Tezpur		2
14	Imphal	44	3
15	Itanagar	05	2
16	Kohima	23	2
17	Chuchuyimlang		2
18	Kolkata	58	4
19	Churachandpur (Manipur)		2
20	Lunglei (Mizoram)		2
21	Patna	02	2
22	Shillong	11	2
23	Srinagar	60	3
24	Jammu		2
25	Shimla	15	2
26	Lucknow	18	2

**Note: Exact number of Employee may vary**