

C2-R3: DATA STRUCTURES THROUGH 'C' LANGUAGE

NOTE:

1. There are **TWO PARTS** in this Module/Paper. **PART ONE** contains **FOUR** questions and **PART TWO** contains **FIVE** questions.
2. **PART ONE** is to be answered in the **TEAR-OFF ANSWER SHEET** only, attached to the question paper, as per the instructions contained therein. **PART ONE** is **NOT** to be answered in the answer book.
3. Maximum time allotted for **PART ONE** is **ONE HOUR**. Answer book for **PART TWO** will be supplied at the table when the answer sheet for **PART ONE** is returned. However, candidates, who complete **PART ONE** earlier than one hour, can collect the answer book for **PART TWO** immediately after handing over the answer sheet for **PART ONE**.

TOTAL TIME: 3 HOURS

TOTAL MARKS: 100
(PART ONE – 40; PART TWO – 60)

PART ONE (Answer all the questions)

1. Each question below gives a multiple choice of answers. Choose the most appropriate one and enter in the “tear-off” answer sheet attached to the question paper, following instructions therein. (1x10)
 - 1.1 $-*+ABC^{\wedge}-DE+FG$ is the prefix equivalent of
 - A) $(A+B)*C-(D-E)^{\wedge}(F+G)$
 - B) $(A+B*C)-(DE)^{\wedge}(F+G)$
 - C) $A+B*C-D-E^{\wedge}(F+G)$
 - D) None of the above
 - 1.2 If the in-order and pre-order traversal of a binary tree are D,B,F,E,G,H,A,C and A,B,D,E,F,G,H,C respectively then, the post-order traversal of that tree is
 - A) D,F,G,A,B,C,H,E
 - B) F,H,D,G,E,B,C,A
 - C) D,F,H,G,E,B,C,A
 - D) C,G,H,F,E,D,B,A
 - 1.3 Which of the following data structure may give overflow error, even though the current number of elements in it, is less than its size
 - A) simple queue
 - B) circular queue
 - C) stack
 - D) None of the above
 - 1.4 “p” is a pointer to the structure. A member “mem” of that structure is referenced by
 - A) *p.mem
 - B) (*p).mem
 - C) *(p.mem)
 - D) None of the above

- 1.5 Considering the following doubly linked list, the appropriate pointer operations to allow insertion of a node (T) at the indicated point are:

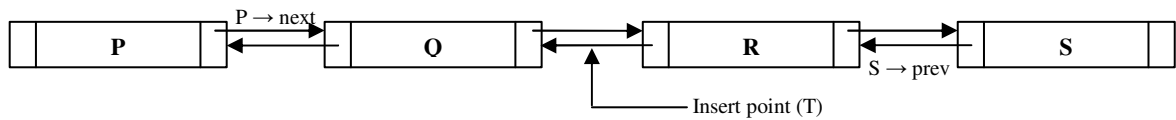

- A) $T \rightarrow \text{next} = Q \rightarrow \text{next}; T \rightarrow \text{prev} = R \rightarrow \text{prev}; Q \rightarrow \text{next} = T; R \rightarrow \text{prev} = T;$
 B) $Q \rightarrow \text{next} = T; R \rightarrow \text{prev} = T; T \rightarrow \text{next} = Q \rightarrow \text{next}; T \rightarrow \text{prev} = R \rightarrow \text{prev};$
 C) $T \rightarrow \text{next} = Q \rightarrow \text{next}; Q \rightarrow \text{next} = T; T \rightarrow \text{prev} = R \rightarrow \text{prev}; R \rightarrow \text{prev} = T;$
 D) Both A and C

1.6 Breadth First Search

- A) Scans all incident edges, before moving on to the next vertex.
 B) Scans adjacent unvisited vertices, as soon as possible.
 C) Same as back tracking.
 D) None of the above.

1.7 Which of the following recurrence relation best describes binary search?

- A) $T(n) = T(n/2) + m$
 B) $T(n) = 2T(n) + m$
 C) $T(n) = 2T(n/2) + n$
 D) None of the above

1.8 Which of the following is a hash function?

- A) Quadratic Probing
 B) Chaining
 C) Open addressing
 D) Folding

1.9 An adjacency matrix representation of a graph cannot contain information of

- A) nodes
 B) edges
 C) direction of edges
 D) parallel edges

1.10 The program section

```
int **p;
p = calloc(5, sizeof(int));
for(i=0; i<5; i++)
    p[i] = calloc(10, sizeof(int));
```

is equivalent to the declaration:

- A) `int p[5][10];`
 B) `int p[10][5];`
 C) `int p[5][5];`
 D) `int p[10][10];`

2. Each statement below is either TRUE or FALSE. Choose the most appropriate one and ENTER in the “tear-off” sheet attached to the question paper, following instructions therein. (1x10)

- 2.1 An algorithm of order $O(\log_2 n)$ is better than another algorithm of order $O(n)$.
- 2.2 Array is an example of a Non-Primitive data structure.
- 2.3 The inorder traversal of a transformed binary tree (transformed from the original to balance the height) and the original binary tree, give same results.
- 2.4 For a sufficiently small number of inputs, the sequential search is more efficient than the binary search.
- 2.5 The external path length of a binary tree is the product of the levels of all the external nodes of its extensions.
- 2.6 The M-way search tree of order n is a general tree in which each node has M or fewer subtrees, and contains one fewer key than it has subtrees.
- 2.7 Positive zero and negative zero are represented as two different numbers in 1's complement method.
- 2.8 All strictly binary trees are almost complete binary trees.
- 2.9 A string of length n bits can be used to represent numbers from 0 to 2^n .
- 2.10 Structures may be passed as arguments to functions using the 'Call by value' technique.

3. Match words and phrases in column X with the closest related meaning/ word(s)/phrase(s) in column Y. Enter your selection in the “tear-off” answer sheet attached to the question paper, following instructions therein. (1x10)

X		Y	
3.1	In C, the pointer type that would best support a heterogeneous linked list.	A.	External nodes
3.2	Binary representation of $(256)_{10}$	B.	Balanced
3.3	Leaf Nodes	C.	Internal search
3.4	A digraph in which the outdegree equals the indegree	D.	$2^n - 1$
3.5	Heap	E.	2^l
3.6	Maximum number of nodes at level '1' in a binary tree [root at level '0']	F.	Void pointer
3.7	The height of a null tree	G.	Complete binary tree
3.8	Most of the table to be searched is stored in auxiliary storage.	H.	Secondary clustering
3.9	Number of nodes in strictly binary tree with 'n' leaves	I.	$O(m \log n)$
3.10	Radix sort ['m' digits and 'n' elements]	J.	$2^n - 1$ nodes.
		K.	Union
		L.	External search.
		M.	Internal nodes.
		N.	-1
		O.	$(2^l - 1)$
		P.	Symmetric
		Q.	1000000
		R.	Almost complete binary tree
		S.	100000000
		T.	$O(m * n)$

4. Each statement below has a blank space to fit one of the word(s) or phrase(s) in the list below. Enter your choice in the “tear-off” answer sheet attached to the question paper, following instructions therein. (1x10)

A.	Probes	G.	Row - major	M.	Nesting depth
B.	Overflow	H.	$\log_2 n - 1$	N.	Midsquare
C.	Sequential	I.	Dangling	O.	Two
D.	$\log_2(n+1) - 1$	J.	Folding	P.	$(2^{p+1} - 1)$
E.	Loops	K.	Direct	Q.	One
F.	$2^{(p-1)}$	L.	Underflow	R.	Null

- 4.1 A _____ pointer is a pointer variable containing the address of a variable that has been freed.
- 4.2 The number of _____ required by a hashing scheme is the average number of table positions that needs to be examined while searching for a particular value.
- 4.3 If the elements of a row are stored next to one another, the array is said to be stored in _____ order.
- 4.4 If a graph has no _____, then the diagonal of an adjacency matrix has all zeroes.
- 4.5 _____ condition in a linked list may occur when attempting to create a node when free space pool is empty.
- 4.6 When the bucket size is _____, collisions and overflows occur simultaneously.
- 4.7 Besides the data fields, each node of doubly linked list contains at least _____ more field(s).
- 4.8 The _____ hash method breaks up a key into several segments that are added or XORed together to form a hash value.
- 4.9 The depth of a complete binary tree, having 'n' nodes, is _____.
- 4.10 _____ access of an element is not possible in linked list.

PART TWO
(Answer any **FOUR** questions)

- 5.
- Show the steps of Heap-Sort (Using a Max – Heap) on the following list:
19, 26, 42, 24, 73, 4, 7, 69, 34
 - Write an algorithm to simulate the POP and PUSH operations in a stack implemented using a singly linked list.

(8+7)

- 6.
- Write a non-recursive algorithm to generate the GCD of two integers.
 - Analyze the time complexity of the Quick-Sort technique.
 - Write an algorithm/program to print the information from each node in singly linked list.

(5+5+5)

- 7.
- Write the algorithm to convert an infix expression to its postfix equivalent. Trace the steps with a suitable example.
 - Convert the following binary tree into an in-threaded tree.

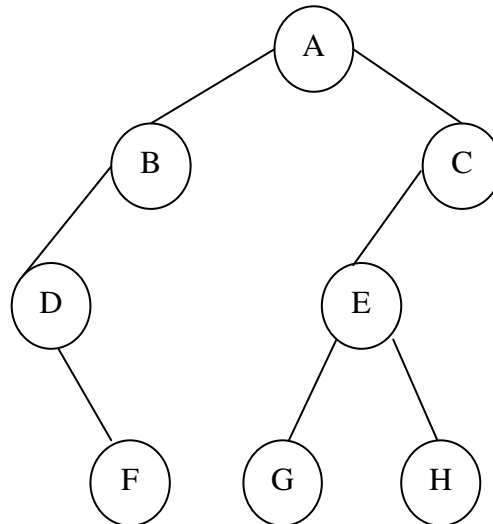

(9+6)

- 8.
- Use Kruskal's algorithm to extract the Minimum Spanning Tree of the graph given below.

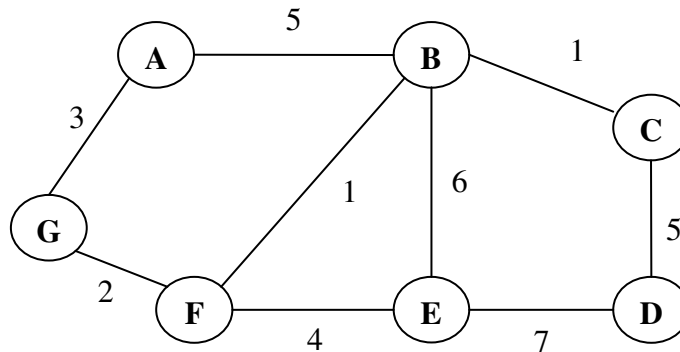

- Using the following traversals, construct the corresponding binary tree.
INORDER : H K D B I L E A F C M J G
PREORDER : A B D H K E I L C F G J M

(8+7)

9.

a) Determine the BFS and DFS traversals of the graph shown below.

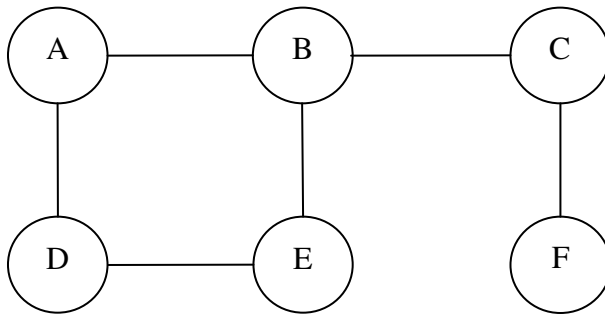

b) Differentiate between the Top-down and Bottom-up approaches to algorithm design.

c) Let A be a two dimensional array declared as `int A[10][15]`. If the first element of array is stored at location 1025, find the address of element `A[3][7]`, considering that the matrix is stored in:

- i) Row Major Ordering
- ii) Column Major Ordering

(5+5+5)