



राष्ट्रीय इलेक्ट्रॉनिकी एवं सूचना प्रौद्योगिकी संस्थान
NATIONAL INSTITUTE OF ELECTRONICS AND INFORMATION TECHNOLOGY



(आई एस ओ 9001:2008 प्रमाणित) (ISO 9001:2008 CERTIFIED)

(इलेक्ट्रॉनिकी और सूचना प्रौद्योगिकी विभाग, संचार और सूचना प्रौद्योगिकी मंत्रालय, भारत सरकार की एक स्वायत्त वैज्ञानिक संस्था)
(An Autonomous Scientific Society of Department of Electronics and Information Technology,
Ministry of Communications & Information Technology, Government of India)

पी.बी. नं. 5, एन.आई.टी. कैम्पस पोस्ट, कालिकट-673601, केरल, भारत P.B. No. 5, NIT Campus Post, CALICUT - 673 601, KERALA, INDIA
Phone : (0495) 2287266, Fax : (0495) 2287168, Web : <http://calicut.nielit.gov.in>

5(137) / 2017 / MPW /

Date: 12-10-2020

NOTICE INVITING TENDER

Sealed item rate quotations are invited for LATTICE TYPE TOWER WIND MILL FOUNDATION CONCRETE WORK AND CABLE LAYING WORK IN CAMPUS-1 NIELIT CALICUT. The work to be subscribed on the envelope with the reference No. and due date. The quotations as accompanied with FMD of Rs. 1450.00/- (Rupees One thousand four hundred and fifty only) in the form of Online deposit slip / Net banking / CDM deposit to NIELIT account (**Account No 10401158037, SBI NITC branch, IFSC SBIN0002207**) or demand draft drawn in favour of the Director, National Institute of Electronics and Information Technology, Calicut (payable at State Bank of India, NITC Branch) should reach to the office of the Executive Director, National Institute of Electronics and Information Technology, NIT Campus Post, Calicut-673601, **On or before 01.00 PM of 21-10-2020** and will be opened at **2.00 PM** on the same day in the presence of the tenderers who wish to be present. The Quotation not accompanied with EMD shall be rejected.

13/10/20

For EXECUTIVE DIRECTOR

- Encl: 1. Schedule of work
2. Terms and conditions
3. Location and structural drawings
4. authorisation letter for e-payments

NIELIT CALICUT
GSTIN : 32AAATD0315M1Z6
 Post Box No. 5, P. O. NIT Campus
 CALICUT – 673601, Kerala
 Tel.: 0495-2287266, 2287166

SCHEDULE FOR LATTICE TYPE TOWER WIND MILL FOUNDATION CONCRETE WORK AND CABLE LAYING WORK

SI No.	REINFORCED CEMENT CONCRETE	Length In meter	Width In meter	Depth In meter	Numbers	LxWxDxNo's In cubic meter	Quantity of work in cubic feet/feet	Charges/Rate Per unit Rs.(per cubic ft/ft as applicable)	Amount in RS.Ps
1	Earth excavation	1.37	1.37	1.47	1	2.997	106		
	മണ്ണ് കുഴിക്കൽ	0.3	0.3	0.66	4				
2	40 mm aggregate + River sand filling 40 മില്ലി മീറ്റർ ചരൽ കല്ലു + പുഴ മണലും നിറയ്ക്കുക	1.37	1.37	0.3	1	0.563	20		
3	Sand filling മണൽ നിറയ്ക്കൽ	1.37	1.37	0.15	1	0.282	10		
4	PCC 1:4:8(1 cement: 4 coarse sand: 8 graded stone aggregate).	1.37	1.37	0.1	1	0.206	7		
	പിസിസി 1: 4: 8 (1 സിമന്റ്: 4 നാടൻ മണൽ: 8 ഗ്രേഡുള്ള കല്ലു).	0.3	0.3	0.05	4				

NIELIT CALICUT
GSTIN : 32AAATD0315M1Z6
 Post Box No. 5, P. O. NIT Campus
 CALICUT – 673601, Kerala
 Tel.: 0495-2287266, 2287166

SCHEDULE FOR LATTICE TYPE TOWER WIND MILL FOUNDATION CONCRETE WORK AND CABLE LAYING WORK

5	RCC 1:2:4(1 cement: 2 coarse sand: 4 graded stone aggregate). Including the cost of centering, shuttering, finishing and reinforcement.	1.37	1.37	1.06	1	2.282	81		
	ആർസിസി 1: 2: 4 (1 സിമന്റ്: 2 നാടൻ മണൽ: 4 ഗ്രേഡുളള കല്ല്). , ഷട്ടറിംഗ്, സ്റ്റീൽ വർക്ക് ഫിനിഷിംഗ്, എന്നിവയുടെ ചെലവ് ഉൾപ്പെടെ.	0.3	0.3	0.81	4				
6	Digging cable trench (Depth 1.5 ft Width 1 ft) and laying cable for 14 meter. Paving brick on the top of the cable and filling the trench by soft soil.(Cable provide by the centre)	14			1		46		
	കേബിൾ ട്രെഞ്ച് കുഴിക്കുന്നതും (ആഴം 1.5 അടി വീതി 1 അടി) 14 മീറ്ററിന് കേബിൾ ഇടുന്നതും. കേബിളിന് മുകളിൽ ഇഷ്ടിക സ്ഥാപിച്ച് ട്രെഞ്ച് മണ്ണിനാൽ നിറയ്ക്കുക (കേബിൾ കേന്ദ്രം നൽകുന്നു)								
	TOTAL AMOUNT IN Rs.(Including all applicable taxes)								
	Discount if any								
	Any other levies/charges								

NIELIT CALICUT
GSTIN : 32AAATD0315M1Z6
Post Box No. 5, P. O. NIT Campus
CALICUT – 673601, Kerala
Tel.: 0495-2287266, 2287166

SCHEDULE FOR LATTICE TYPE TOWER WIND MILL FOUNDATION CONCRETE WORK AND CABLE LAYING WORK

Total amount (Including all charges) in Rs.	
Payment terms	
Time required to complete the work	
Quotation validity	
Warranty	
Others , if any	
PAN/GST Registration No, if any	
Email ID	
Mobile No.	

Quotation form include location map and structural drawing

ലൊക്കേഷൻ മാപ്പും ഘടനാപരമായ ഡ്രോയിംഗും ഫോമിൽ ഉൾപ്പെടുന്നു

- **NB: Contractor may visit the site and inspect before quoting to know the actual site condition**
യഥാർത്ഥ സൈറ്റ് അവസ്ഥ അറിയാൻ കരാറുകാരന് സൈറ്റ് സന്ദർശിക്കേണ്ടതാണ്
- **NB: The work inclusive of all material and labour**
തുക എല്ലാ മെറ്റീരിയൽസ് ചാർജും ലേബർ ചാർജും ഉൾപ്പെടുത്തി ആയിരിക്കണം
- **NB: The work will be carried out on measurement basis.**
വർക്ക് അളവ് അടിസ്ഥാനത്തിലായിരിക്കും കണക്കാക്കുക
- **TDS IT/GST will be deducted as per rules**

PROPOSED SITE DRAWING FOR LATTICE TYPE
WIND MILL

MKPI
site drawing for the
proposed wind mill installation
is given below. Please confirm
30/7/20
PTS

Mu
30/6/20.

good; ok
ahead -
ED/M. d. d. ill.
30/6/20.

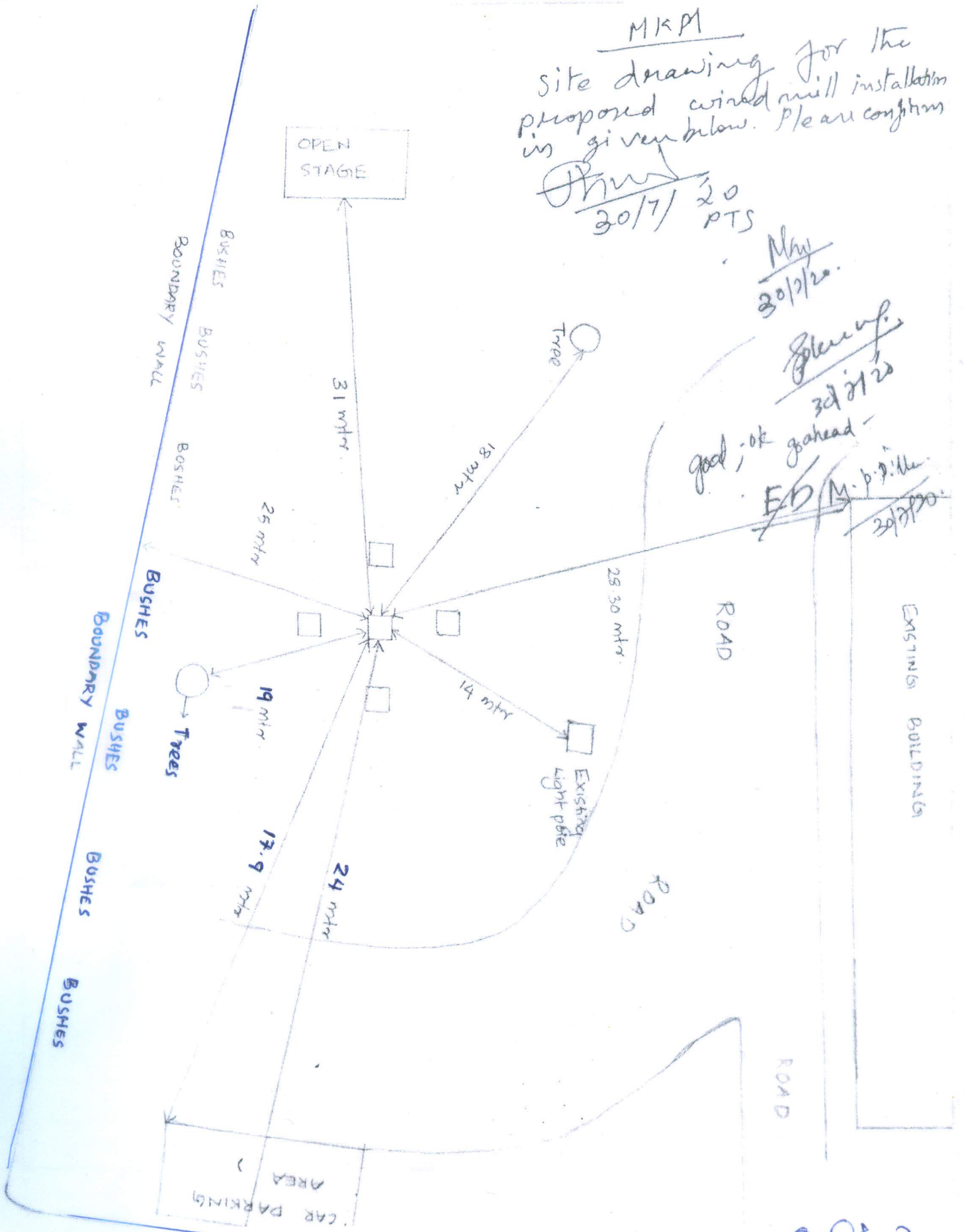

D. D.

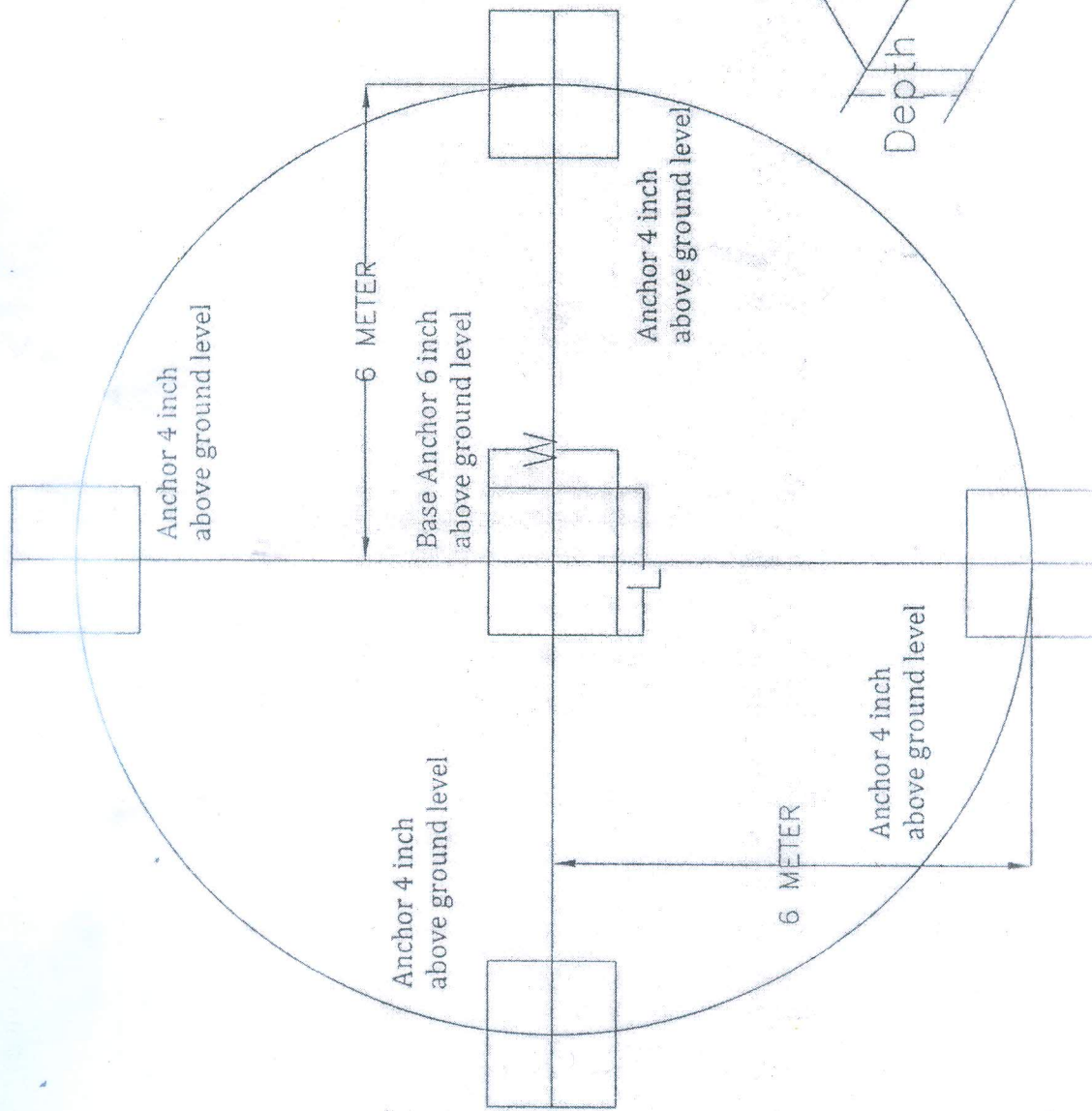

Handwritten signature

L-1 meter x W-1 meter x H-1 meter

FOUNDATION LAYOUT

LATTICE TYPE TOWER FOUNDATION DETAILS

6 INCH ANCHOR FOUNDATION (1 NO)

Side / Front View

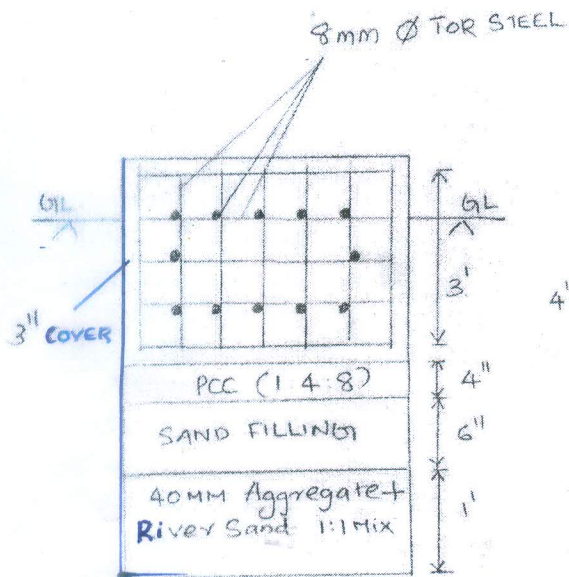

Top View

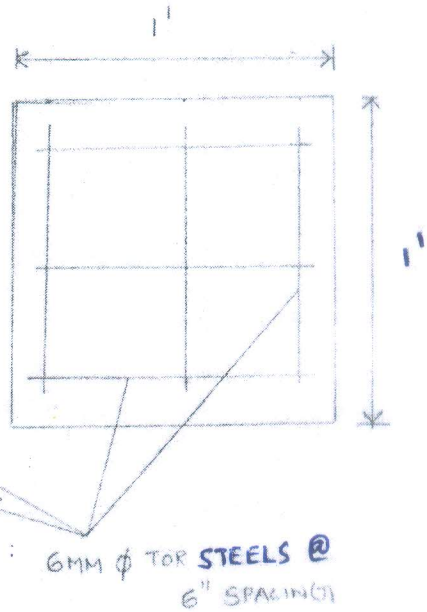
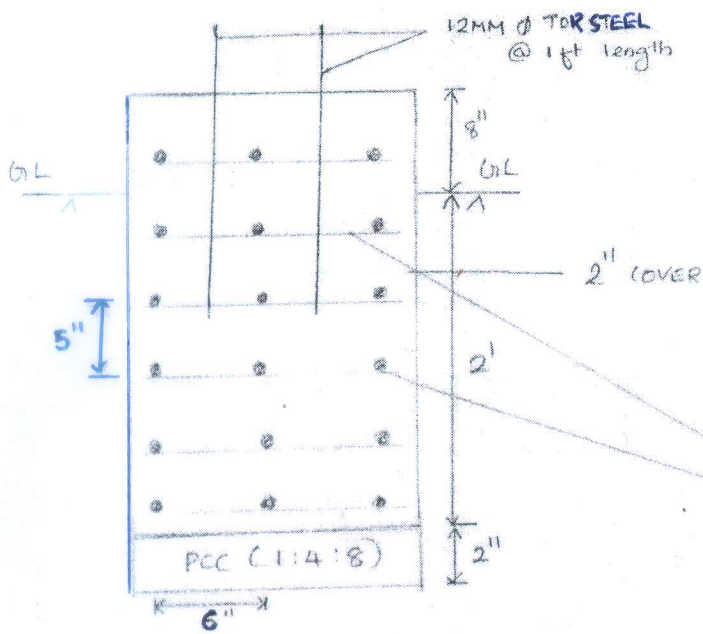
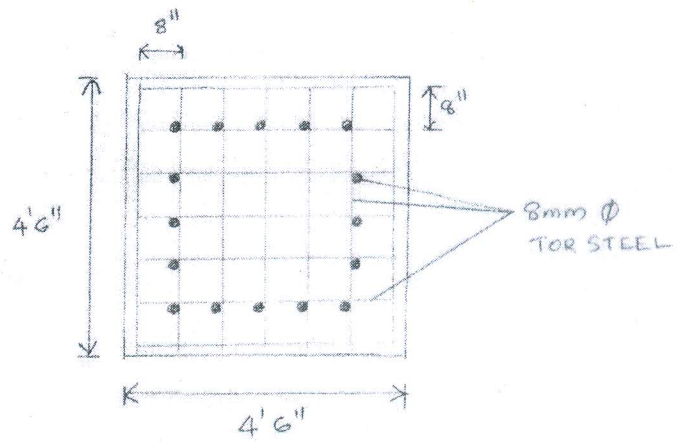

Side / Front View

Top View

(Signature)
JELLY

TERMS & CONDITIONS FOR WORKS

CDS/CA/6.3.0/F 07/R2

1. The quotation shall be in the prescribed form and shall be valid for a minimum period of three months from date of its opening. Should the tenderer modify or withdraw his quotations within the said period of 3 months, from the date of its opening, the earnest money deposited by the tenderer shall be forfeited.
2. The Director shall be the Accepting officer, hereinafter referred to as such, for the purpose of the contract.
3. All rates shall be quoted in the prescribed form.
4. All the rates must be filled-in, in both words and figures.
5. The quotations shall be accompanied by the Earnest Money **Rs.1450.00/- (Rupees One thousand four hundred and fifty only)** in the form of Online deposit slip / Net banking or demand draft drawn in favor of the Director, National Institute of Electronics and Information Technology, Calicut, payable at State Bank of India, NITC Branch.
6. On acceptance of the quotation, earnest money will be treated as part of the Security Deposit. Failure of the successful tenderer to carry out the quoted work shall entail in forfeiture of the total earnest money/security deposit.
7. The amount of security deposit including the amount of earnest money shall be 5% of the tendered cost of the work. Upon acceptance of the quotation, the successful tenderer shall within 10 days of the written acceptance of his quotation, deposit with NIELIT, Calicut an amount equivalent to 5% of the value of the works at the accepted rates.
8. NIELIT Calicut will return the earnest money without any interest to unsuccessful tenderers.
9. The time of completion of the work shall be by **15 Working Days**
10. In case the Contractor fails to complete the work on or before the stipulated completion time, he shall be liable to pay 1% of the total order value as liquidated damages for each day of default.
11. If the work cannot be completed within the stipulated completion time due to any unforeseen or unavoidable reasons beyond the control of the Contractor, he shall seek prior permission from the Competent Authority, well before the stipulated completion time itself, for delayed execution of the work, clearly stating the reasons for delay as well as fresh date of completion.
12. There will be 15 days' time from the date of issue of the acceptance letter for commencement of work.
13. The defect liability period will be of **one year** duration, upon satisfactory completion of which, the security deposit will be refunded to the tenderer.
14. The tenderer is required to comply with the provision of all the Acts/legislations of the Govt. relating to the Labor laws, and the rules and regulations made there under from time to time and to submit at the proper time, all particulars and statements required to be furnished to the Labor authorities concerned.
15. The tenderer shall give all necessary personal superintendence during the execution of the works.
16. No materials shall be supplied by NIELIT Calicut except those mentioned.
17. The contractor shall make his own arrangements for water required for the work and nothing extra will be paid to him for the same. If the contractor is unable to make his own arrangements, on written request, the Centre may consider water supply for the work and 1% of the value of the total work done towards water charge shall be deducted from the bill.
18. Payment shall be released after satisfactory completion of the work. The work is to be carried out in accordance with the CPWD specifications, rules and regulations.
19. The successful tenderer, within one week of award of the work to him shall submit to the Director an illustrative and suitable colored work-time chart.
20. The materials to be used in electrical installations shall be of approved make and quality as specified in the schedule of quantities and shall conform strictly to the relevant Indian Standard Specifications.
21. (1) During the execution of work, unless otherwise specified, the contractor shall at his own cost provide the materials and execute all shoring, timbering and structures, excavations and works and shall ensure that no damage, injury or loss is caused or is likely to be caused to any person or property.
(2) The Contractor shall be responsible to take all precautions to ensure the safety of the public employee/property and shall post watch and guard as may be required by the Engineer-in-charge.
(3) The Contractor shall employ adequate number of technically qualified personnel as per Central Government/CPWD Rules for proper supervision of the work.
(4) The technical staff should be available at the site, whenever required by NIELIT Calicut to take instructions.

- (5) In case the contractor fails to employ these technical staff as aforesaid he shall be liable to pay a reasonable amount not exceeding Rs.750/- for each month of default.
22. Sales tax or any other tax on materials in respect of his contract shall be payable by the contractor and NIELIT Calicut shall not entertain any claim whatsoever in this respect.
 23. The work shall be carried out as per the drawing showing the layout of internal electrical installation. The NIELIT Calicut reserves the right to make any changes or modifications in the layout. No claim from the contractor on account of any change in layout shall be entertained by NIELIT Calicut.
 24. The Contractor shall prepare necessary drawings for approval from Electrical Inspectorate.
 25. NIELIT Calicut is not bound to accept the lowest quotation and the accepting officer may reject in part or in full or all the quotations without assigning any reasons.
 26. In the event of any dispute, the decision of the accepting officer shall be final and binding on all concerned.
 27. Statutory taxes/levies, viz., Income Tax, GST etc. shall be deducted at source as per the prevailing rules.
 28. The contractor shall comply with the requirements of all the prevailing tax laws in force such as Income tax act, GST etc.



For NIELIT CALICUT

The above terms and conditions accepted
Date:

(Signature, Name and Address of the Contractor)

AUTHORISATION LETTER FOR e-PAYMENTS

TO

Director
NIELIT, CALICUT
PB No 5, NIT CAMPUS POST,
CHATHAMANGALAM
CALICUT- 673601
KERALA, INDIA

Dear Sir,

Sub: Bank Account Details for Electronic payment by RTGS/NEFT/e-TRANSFERS - Reg.

I/we authorize you to effect all the payments due to me/us by way of e-payment through RTGS/NEFT/e-TRANSFERS to our Bank Account, subject to RBI Guidelines, as per the details given below. I/We have also noted that the e-payments made by you shall be proper discharge of liability statutorily, in terms of agreements/contracts entered.

Fill All Details in LEGIBLE CAPITAL LETTERS (wherever applicable) * Fill up the details which are relevant to you/your organization.	1	Bank Account Number																			
	2	Account Holder's /Beneficiary Name																			
	3	Whose Account is this? Company/self/firm/proprietor/others - specify																			
	4	Beneficiary Address																			
	5	e-mail Address of Beneficiary																			
	6	Contact Mobile Number of Beneficiary																			
	7	Beneficiary Bank Name																			
	8	Branch of Beneficiary Bank																			
	9	IFSC CODE of Beneficiary Branch																			
	10	AADHAR CARD Number (in case of individuals/proprietary business)/PAN																			

I/we hereby declare that the particulars given above are correct and complete and, if the transaction is delayed or not effected at all for reasons of incomplete or incorrect information I/we would not hold NIELIT, Calicut responsible and I/we agree to indemnify NIELIT, Calicut from any loss or damages due to incomplete or incorrect information provided by me/us.

Authorized Signatory's
(Signature)

Thanking you,

Name

Place :

Official Rubber Stamp/Seal

Date: